

## Rexon ERA DUO 3

The Rexon ERA DUO 3 turnstile is a dual passage premium quality steel construction designed for high security applications where high throughput unmanned pedestrian access is required. With an anti-corrosive finish the Rexon ERA DUO 3 is suitable for both interior and exterior use.

### MAIN FEATURES

- Maximum security – dual brake system
- Automatically adapts the rotation speed to the users
- Space saving dual passage design
- Silent and smooth operation

### DIMENSIONS

Unit height: 2520mm  
Unit width: 2360mm  
Passage height: 2100mm

### NUMBER OF WINGS

3 Wings (120°)

### PASSAGE WIDTH

Passage Width: 580mm

### FRAME

Hot-dip zinc galvanised

### CENTRAL COLUMN/ BARS

Hot-dip zinc galvanised

### TOP PANEL

Hot-dip zinc galvanised, powder coated finish in RAL Colour

### BARRIER TYPE

11 Tubular bars Ø 40mm (with black plastic covering caps)

### POWER SUPPLY

13.8V DC/ 24V AC/ 230V AC

### COMMUNICATION INTERFACE

RS485/ USB/ Ethernet



### RANGE OF OPERATING TEMPERATURE

-20°C to +50°C (IP 65)  
-40°C to +60°C (IP 65) with Extreme outdoor package\*

\*Optional Feature

### OPERATING MODES

Operating modes can be configured in either direction.

1. Free Passage (in/out)
2. Access Controlled Passage
3. Permanently locked

### OPERATING ENVIRONMENT

Indoor/ outdoor

### EMERGENCY MODE

On emergency release Fail Safe will put the turnstile into free flow in both directions

## OPTIONAL ACCESSORIES

- LED lane light
- Integrated 3rd party terminals
- Passageway light
- Canopy
- Ramp LT
- Solid steel ended bars
- Mounting frame
- Extreme outdoor package
- Economy version with hot-dip galvanized steel rotor and tube

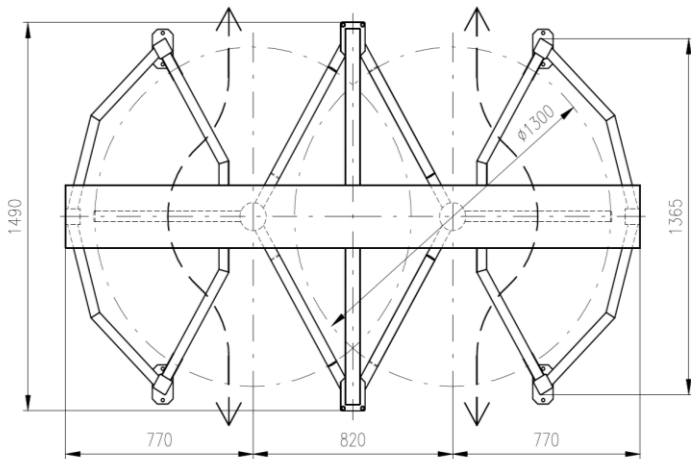
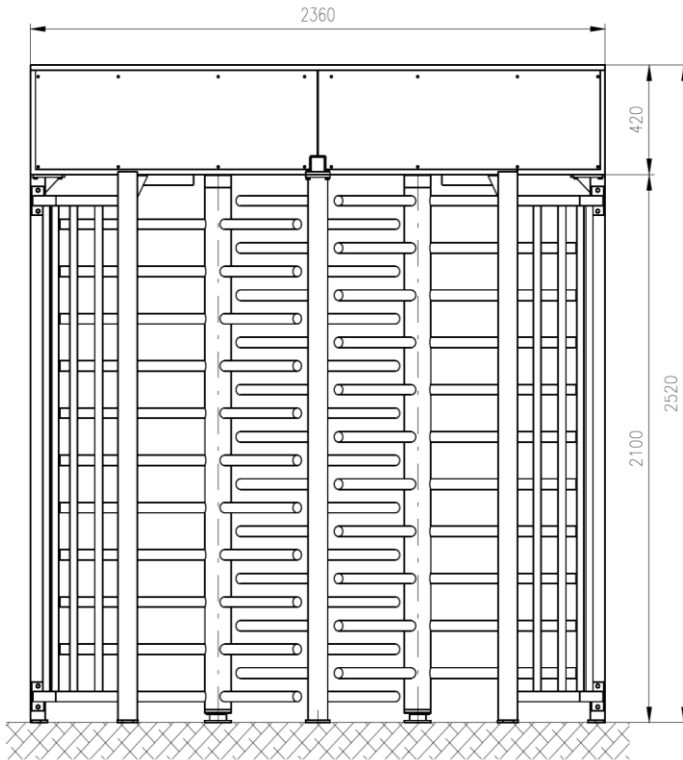

As our policy is to continually improve the products we offer, we reserve the right to amend specifications without prior notice. Further product drawings are available on request