

QUICK START GUIDE

NK-1

NK-1 Wireless Access Point Controller / NK-1 Network Cloud Patroller
Version 1.2



SectorMaxx™



TruStream™



SmartWav™

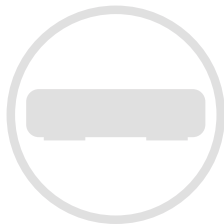

Contents

Package contents	3
Installing the NK-1	5
Configuring the NK-1 Wireless Access Point Controller	6
Step 1: Logging in	7
Step 2: Changing the IP address of the controller	11
Step 3: Running the Wizard	12
Access point overview	16
Configuring the NK-1 Network Cloud Patroller	17
Step 1: Logging in	17
Step 2: Changing the IP address of the patroller	19
Creating a BakPak Cloud Account from the cloud	20
Configuring the NK-1-CP	22
Technical Support	24

Package contents

Contents are based on the model of your NK-1. Please refer to the installation manual of your product.

NK-1

The NK-1 model can be identified by following labels:

Wireless Access Point Controller

You can find the “Controller” label on the NK-1’s rear panel and “Controller FW loaded” label on the box.



Controller



FW loaded

Refer to following label that indicates how many access points the controller is able to manage. It follows your order of the NK-1.

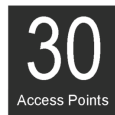
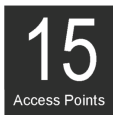
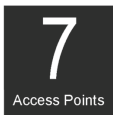
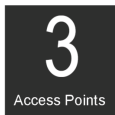

Network Cloud Patroller

You can find the “Patroller” label on NK-1’s rear panel and the “Patroller FW loaded” label on the box.



NK-1 Default Settings

IP Address: **192.168.1.240**

Username/Password: **pakedge/pakedgen**

Installing the NK-1

Tools required:

- Phillips screwdriver (if using rack-mount brackets)
- Computer with Ethernet interface and a web browser (an integrated DB-9 port or USB-to-Serial adapter may be necessary if you would like to use the console interface.)
- Ethernet cable

Installation

- 1 Open the box and remove the NK-1.
- 2 If mounting the NK-1 in a standard 19" AV rack, attach the included rack-mount brackets to the sides of the NK-1. If not mounting to a rack, ensure that the NK-1 is physically mounted near power and network connections (such as a backbone switch or firewall/router).

- 3 Connect power to the device.
- 4 Connect an Ethernet cable from your computer to the **LAN** port on the NK-1.

You are now ready to configure the NK-1 to an IP address that matches your network.

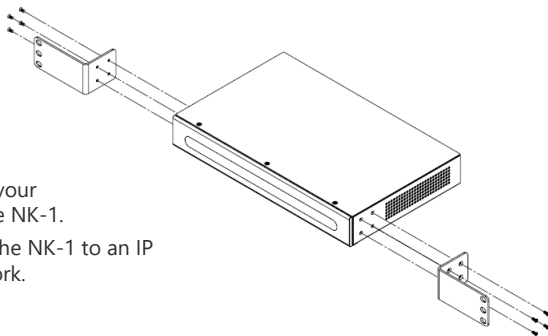

Configuring the NK-1 Wireless Access Point Controller

If your NK-1 model is the NK-1 Network Cloud Patroller, please skip to the section “Configuring the NK-1 Network Cloud Patroller.”

There is separate NK-1 controller firmware for W6/W7 and WK/WX. The following screens shown may look different in NK-1 W6/W7 controller firmware.

Step 1: Logging in

- 1 Connect the NK-1 to power and press the power switch on the rear panel. The **PWR** LED will light up.
- 2 Connect a computer to the NK-1 through an Ethernet cable. Enter **192.168.1.240** into the address bar of your web browser. A login page opens.
- 3 In the *username* box, type **pakedge**. In the *password* box, type **pakedge**, then click **Login**.



NOTE: If your computer is not set to the default IP scheme of the NK-1 (192.168.1.X), you must first configure the TCP/IP settings on your computer to log in to the NK-1 through a web browser.

Using Windows 10

- 1 Under **Control Panel, Network and Internet**, click **View Network Status and Tasks**.
- 2 On the left panel, click **Change Adapter Settings**, right-click **Local Area Connection**, then click **Properties**.
- 3 Select **Internet Protocol Version 4 (TCP/IPv4)**, then click **Properties**.
- 4 Select **Use the Following IP Address** and enter the following information:
IP address: **192.168.1.10**
Subnet mask: **255.255.255.0**
- 5 Additional settings can be left blank.
- 6 Click **OK**, then **Close**.

Internet Protocol Version 4 (TCP/IPv4) Properties

General

You can get IP settings assigned automatically if your network supports this capability. Otherwise, you need to ask your network administrator for the appropriate IP settings.

Obtain an IP address automatically

Use the following IP address:

IP address: 192 . 168 . 1 . 10

Subnet mask: 255 . 255 . 255 . 0

Default gateway: . . .

Obtain DNS server address automatically

Use the following DNS server addresses:

Preferred DNS server: . . .

Alternate DNS server: . . .

Validate settings upon exit

Advanced...

OK Cancel

Using OS X

- 1 Under **System Preference**, click **Network**.
- 2 On the left panel, click **Ethernet** (or **Thunderbolt Ethernet** on newer Macs), then select **Manually** from the drop-down menu.
- 3 Enter the following information:
IP Address: **192.168.1.10**
Subnet Mask: **255.255.255.0**
Additional settings can be left blank.
- 4 Click **Apply**.

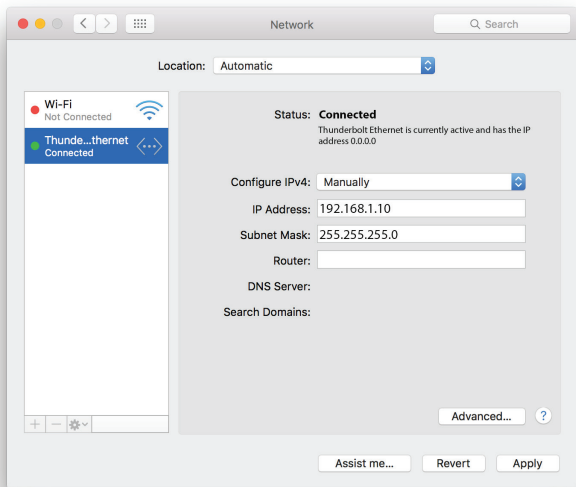

The following page will display when logged in to the NK-1 Wireless Access Point Controller:

NK-1-CG1 Dashboard Settings Dealer Tools Wizard Uptime: 6m Jan 04, 2016 06:45pm Logout

Dashboard Widgets

Welcome to your
NK-1-CG1
Hostname: Pkedge@NK-1
Serial Num: INTERNAL ONLY
Firmware: 4.20-5-debug
License: INTERNAL USE
MAC: 90a7c1960007
IP: 192.168.1.240
Netmask: 255.255.255.0
Gateway: 192.168.1.99

Reports Access Points Site Survey Wireless Optimization

Advanced AP Deployment Help

2.4 GHz: 0 Client(s)
5.8 GHz: 0 Client(s)
90a7c10807c6

2.4 GHz: 0 Client(s)
5.8 GHz: 0 Client(s)
90a7c10811fa

Refresh Dashboard Reboot Controller Shutdown Controller

Step 2: Changing the IP address of the controller

- 1 After you are logged in to the controller, hover over **Macrocell Controller** under **Setting**, and click **LAN Settings**.
- 2 Fill in the **IP** address, **Netmask** (subnet mask), **Gateway**, and **Hostname** information, then click **Save** to implement your changes.

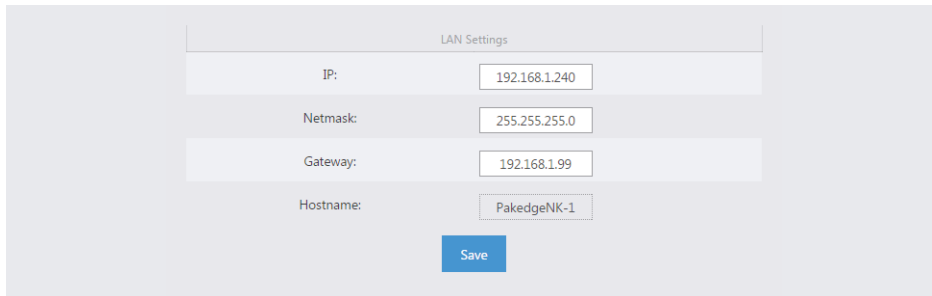

LAN Settings	
IP:	<input type="text" value="192.168.1.240"/>
Netmask:	<input type="text" value="255.255.255.0"/>
Gateway:	<input type="text" value="192.168.1.99"/>
Hostname:	<input type="text" value="PakedgeNK-1"/>
<input type="button" value="Save"/>	

Now that your NK-1 Wireless Access Point Controller has the correct IP information and matches your network's scheme, you are ready to connect it to either a switch or directly to the router and set up the wireless system.

Step 3: Running the Wizard

The Wizard will discover, manage, and configure your access points (APs), making it a quick and easy tool to get your wireless network up and running.

If this is your first time logging in to the controller, you will be prompted to run the **Wizard**.

Otherwise, log in to the controller and hover over the *Wizard* menu and click **Run Wizard**. Click **Start the Easy Wizard** to begin the wizard setup.



Start the Easy Wizard

Setting the IP address and updating the firmware

If your wireless access points have duplicate IP addresses, the controller will ask you to configure the IP address of your access point.

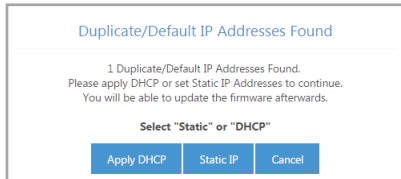



- 1 Click **Apply DHCP** to get the dynamic DHCP from your router in the network. Make sure your router is on and can assign IP addresses correctly.

- OR -

Click **Static IP**, input your desired IP address range in the blanks, and click **Set**. If the IP address of your wireless access points has been configured, this step will be skipped.

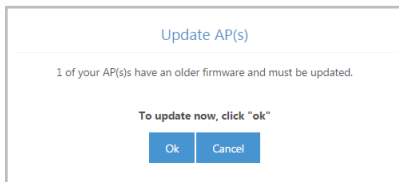

The access points must all be on the same firmware version. If there is any inconsistency in the firmware version, the controller will notify you as follows:

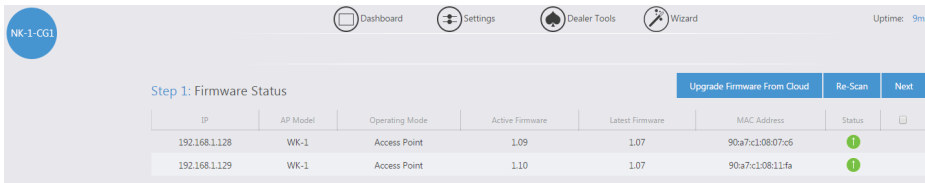

- Click **OK** to upgrade to the latest AP firmware. After the firmware upgrade is completed, you will be redirected to the AP-Firmware update page. The icon  indicates the access points that have an older firmware and which version they should be updated to.
- Select the highlighted APs and click **Upgrade**. After the process is complete, all of your access points should display a green icon like this .



Step 1: Firmware Status

IP	AP Model	Operating Mode	Active Firmware	Latest Firmware	MAC Address	Status	
192.168.1.128	WK-1	Access Point	1.09	1.07	90a7c1:08:07:c6		<input type="checkbox"/>
192.168.1.129	WK-1	Access Point	1.10	1.07	90a7c1:08:11:fa		<input type="checkbox"/>

Buttons: Upgrade Firmware From Cloud, Re-Scan, Next

- Click **Next** to continue to the next step.

Discovering and managing AP(s)

The controller will detect the DHCP server on the network, which is usually a router.

- Click **Next** to continue.

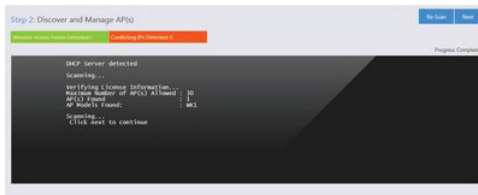

Step 2: Discover and Manage AP(s)

Program Complete

```

DHCP Server detected
Scanning...
Verifying License Information...
Maximum Number of AP(s) Allowed: 30
AP(s) Found: 1
AP Model Found: w1
Scanning...
Click Next to continue
  
```

Buttons: Re-Scan, Next

Setting Global Configuration

- 1 The Wizard will ask you how many SSIDs you would like to configure. You can configure up to 18 SSIDs (8 on 2.4 GHz and 8 on 5 GHz, in addition to a guest SSID for each band). After you have selected the number of SSIDs, you will be able to configure them individually.

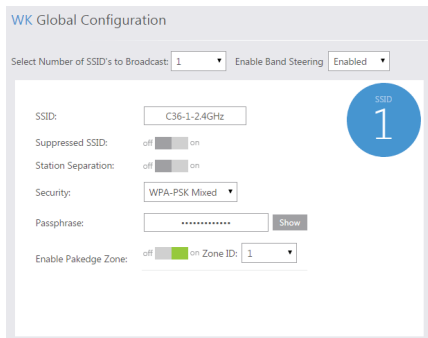

The screenshot shows the 'WK Global Configuration' window. At the top, there are two dropdown menus: 'Select Number of SSID's to Broadcast' set to '1' and 'Enable Band Steering' set to 'Enabled'. Below these are several configuration options for the SSID:

- SSID: C36-1-2.4GHz
- Suppressed SSID: off (checkbox) on (checkbox)
- Station Separation: off (checkbox) on (checkbox)
- Security: WPA-PSK Mixed (dropdown)
- Passphrase: [masked] Show (button)
- Enable Packed Zone: off (checkbox) on (checkbox) Zone ID: 1 (dropdown)

A blue circular callout with the number '1' and the text 'SSID' is positioned to the right of the SSID field.

- 2 *Band steering* moves 5 GHz-compatible client devices to that frequency. If you do not enable band steering, make sure that you use different SSID names for your 2.4 GHz and 5 GHz wireless.
- 3 After you have selected the number of SSIDs you want, you can configure the SSID name, security, password, and more.
- 4 Packed Zone (WK/WX version only) is the Packedge pre-configured VLAN settings. Ensure the Packedge Zone configuration matches the settings of your Packedge switches and routers.

Access point overview

After the Wizard completes, you will be directed to the Access Point page.

- 1 Click **Manual Setup** to see the status of the access points.

AP Location	Type/Serial	Model	IP	Operating Mode	Channel	MAC Address	Power	License	Status	<input type="checkbox"/>
Click to edit	Type: Indoor S/N: WK-1T0415A10634	WK-1	192.168.1.128	Access Point	24 1	90:a7:c1:08:07:c6	24 Max dBm			<input type="checkbox"/>
					5 44		5 Max dBm		Online	
Click to edit	Type: Indoor S/N: WK-1T0415A11087	WK-1	192.168.1.129	Access Point	24 1	90:a7:c1:08:11:fa	24 Max dBm			<input type="checkbox"/>
					5 44		5 Max dBm		Online	

NOTE: For more detailed instructions and an explanation of the options under the NK-1 controller GUI, refer to the NK-1 User's Manual.

Configuring the NK-1 Network Cloud Patroller

Step 1: Logging in

- 1 Connect the NK-1 to power and press the power switch on the rear panel. The PWR LED will light up.
- 2 Connect a computer to the NK-1 through an Ethernet cable. Enter **192.168.1.240** into the address bar of your web browser. You should see a login page. In the *USERNAME* box, type **pakedge**. In the *PASSWORD* box, type **pakedgen** and click **Login**.

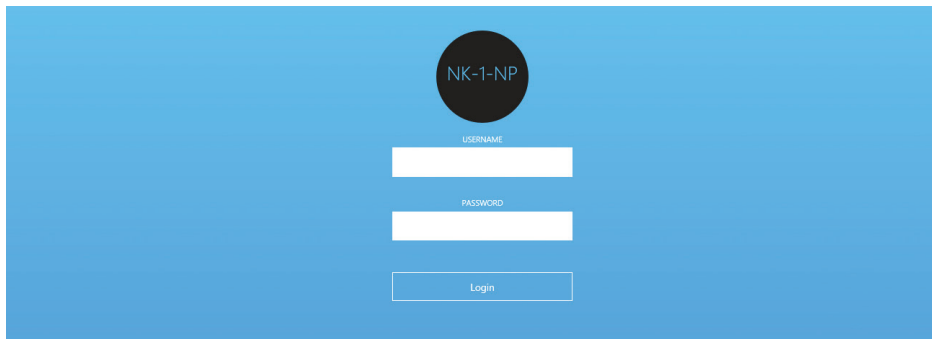

The screenshot shows a login interface for the NK-1 Network Cloud Patroller. It features a blue background with a central black circle containing the text "NK-1-NP". Below the circle are two white input fields: the first is labeled "USERNAME" and the second is labeled "PASSWORD". At the bottom center, there is a white button labeled "Login".

NOTE: If your computer is not set to the default IP scheme of the NK-1 (192.168.1.X), you must first configure the TCP/IP settings on your computer to log in to the NK-1 through a web browser. Refer to page 8-9 on how to configure the TCP/IP settings on your computer.

The following page will display when logged in to the NK-1 Network Cloud Patroller:

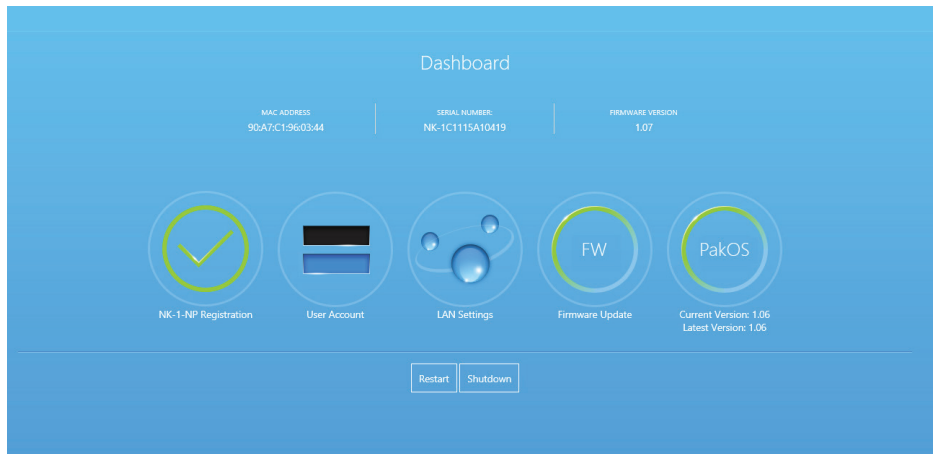

Step 2: Changing the IP address of the patroller

- 1 Log in to the Patroller and click **LAN Settings**.
- 2 Enter the IP address, subnet mask, and default gateway, then click **Update**.

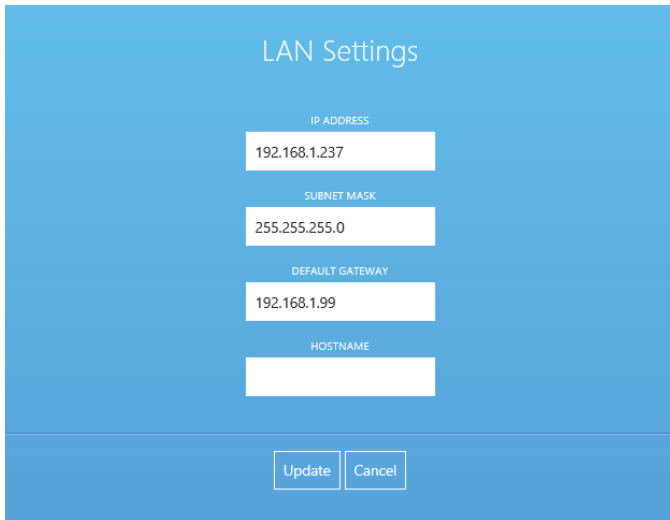

The screenshot shows the 'LAN Settings' configuration page. It features a blue background with white text and input fields. The settings are as follows:

Field Label	Value
IP ADDRESS	192.168.1.237
SUBNET MASK	255.255.255.0
DEFAULT GATEWAY	192.168.1.99
HOSTNAME	

At the bottom of the page, there are two buttons: 'Update' and 'Cancel'.

Creating a BakPak Cloud Account from the cloud

- 1 Open a web browser and enter the following URL: <https://mybakpak.com>



- 2 Click [Create a] **Dealer Admin Account**.

The *Register for myBakpak* page opens.

 Register for myBakpak
A **dealer code** is required to create an admin account.

- If you have already created an admin account, please go back to login page and use that account to log in.
- If you are a first time dealer and a first time BakPak user and do not yet have a Dealer Code, please contact pakedge sales at (650) 385-8702 to request a Dealer Code. Be ready to verify your:
 - dealer name
 - pakedge account number
 - email address.
- If you already have your Dealer Code, proceed with registration.

Email Address	<input type="text"/>	Password	<input type="text"/>
[Limit 30 Characters]		Confirm Password	<input type="text"/>
Confirm Email Address	<input type="text"/>		
Timezone	<input type="text" value="US/Eastern"/>	Enter Dealer Code	<input type="text"/>

3 Follow the on-screen instructions to get your Dealer Code.

4 Enter your email address, new password, time zone, and Dealer Code, then click **Register**.

Configuring the NK-1-CP

The NK-1-CP includes both the NK-1-CG1 Wireless Access Point and the NK-1-NP Network Cloud Patroller. The default settings are the same as for NK-1-CG1 and NK-1-NP.

The following page displays when logged in to the NK-1-CP:

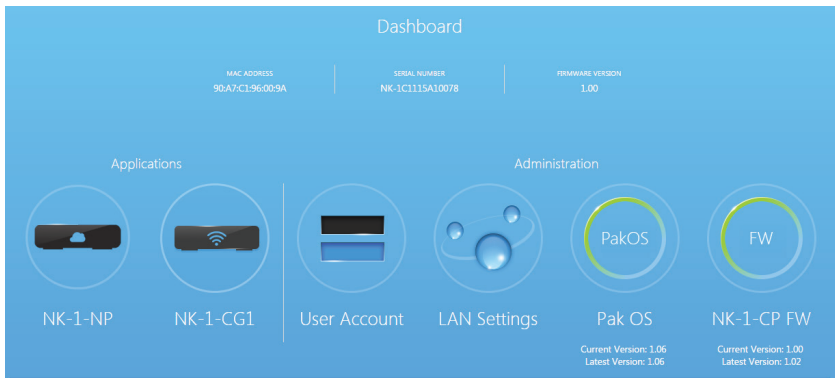

- 1 To change the IP address of your NK-1-CP, click **LAN Settings**.
- 2 To configure the other settings, refer to the sections "Configuring the NK-1 Wireless Access Point Controller" and "Configuring the NK-1 Network Cloud Patroller" in this guide.

Technical Support

For technical help:
www.pakedge.com/portal
support@pakedge.com
(650) 385-8703

For non-technical inquires:
customerservice@pakedge.com
(650) 385-8701

For regulatory information:
www.pakedge.com/regulatory

pakedgedevice&software inc

3847 Breakwater Avenue, Hayward, CA 94545-3606
Main: (650) 385-8700 Fax: (650) 685-5520

www.pakedge.com
sales@pakedge.com
©2016 Pakedge Device & Software Inc. All rights reserved.



DOC-00230-B 2016-07-22 MS