



# EasyGate

Swing & Sliding Speed Gates



The EasyGate speed gate range represents the latest innovation in entrance control systems, combining high security with user comfort. The combination of stainless steel together with glass, wood or other material (corian, black stainless steel or others) create an attractive aesthetic design. The powerful drive unit provides a large number of operating modes, good accessibility and a high level of personal safety.

A wide range of cabinet shapes, design and surface finishes, ensures that the turnstile will seamlessly fit into any interior decor.



## SWING TECHNOLOGY

combines the slim design of the EasyGate cabinet with a high speed drive unit. Our designers focused on fitting swing speed gates to any location whilst keeping the ability to implement a wide range of optional accessories without limitation. Moreover our technology offers different Swing models for indoors, as well as outdoor installation with the additional option of altering the cabinet length and glass wing barrier height which provides the perfect solution for all projects.

## SLIDING TECHNOLOGY

also known as speed gate technology has been developed by COMINFO to the highest design and security level. Sliding opening provides an intuitive and easy passage for the users. These speed gates are adaptable and a various accessories and terminals or readers are easily integrated. The large variety of shapes and materials used for each sliding speed gate makes this turnstile suitable for any interior.

## CONTENTS

---

### Swing Speed Gate Technology

- 4 EasyGate Superb
- 6 EasyGate Elite / EliteS
- 8 EasyGate LC
- 10 EasyGate IM
- 12 EasyGate BV
- 14 EasyGate SPT-G / R
- 16 EasyGate SPD-G / R
- 18 EasyGate SG / SR 1000 & 1320

### Sliding Speed Gate Technology

- 20 EasyGate LG
- 22 EasyGate BG
- 24 EasyGate LX / LH
- 26 EasyGate FL / FH

### Special Applications

- 28 EasyGate SPT Outdoor
- 30 EasyGate WN
- 32 EasyGate SPA
- 34 EasyGate SBG
- 36 e-Gate
- 38 EasyGate SPT-G Bike / SPT-R Bike
- 40 EasyGate SPT-G / SPT-R Bike Outdoor
- 42 Interlock gate

### 44 Specification Overview

### 48 Options & Accessories

### 50 Project Design

### 51 EasyGate Integration



# EasyGate Superb

## Type

Swinging technology  
 1 wing / 2 wings  
 Square front

## Safety & Security Detection

- 24 pairs of IR sensors
- Safety & Security levels
- Tailgating / Cross over detection

## Dimensions

Cabinet height	990 mm	38.98"
Cabinet length	1 580 mm	55.12"
Cabinet width	99 mm	5.95"
Barrier height standard	990 mm	38.98"
Barrier height max.	1 800 mm	70.87"
Passage width standard*	650 mm	25.59"
Passage width max.*	1 100 mm	43.31"
	<i>for height of glass wing up to 1 400 mm</i>	
	max 920 mm	36.22"
	<i>for height of glass wing up to - 1 800 mm</i>	

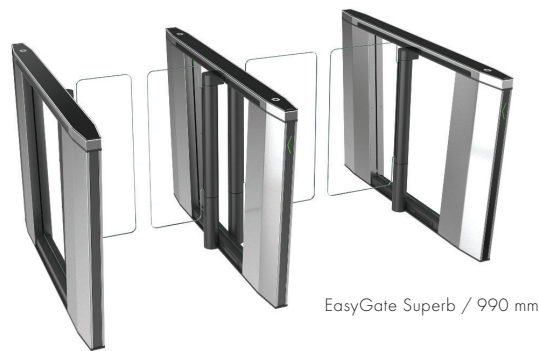

EasyGate Superb / 990 mm

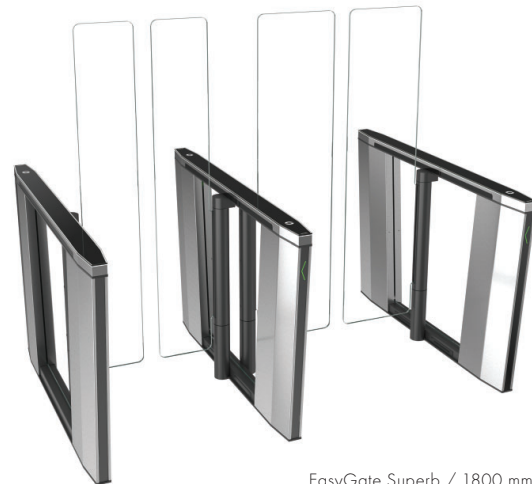

EasyGate Superb / 1800 mm

\* For 2 wings type



### Standard Materials and Colours

Frame	black RAL
Covers	brushed stainless steel
Top Lid	black glass
Barriers	tempered glass barrier panels (10 mm/0.39")
Side Infill Panel	tempered glass panels (6 mm/0.24")

### Operating Environment

Indoor

### Drive Mechanism

Fail-Safe

MCBF 5 000 000

### Stand-by Power Consumption

25,9 W

### Emergency Mode

Open automatically in the exit direction

### Optional Accessories

RFID reader bracket (flush mounted)

Access Light / Lane Light / Passage Light

WAV player

Pressure sensing top

RF remote control

EasyTouch / TouchPanel / T-MON SW

SuperCap (emergency power back-up)

Alternative surface finishes / Optional top Finishes

Integration of liftCall / Card collector / BarCode scanner

Ramp LT

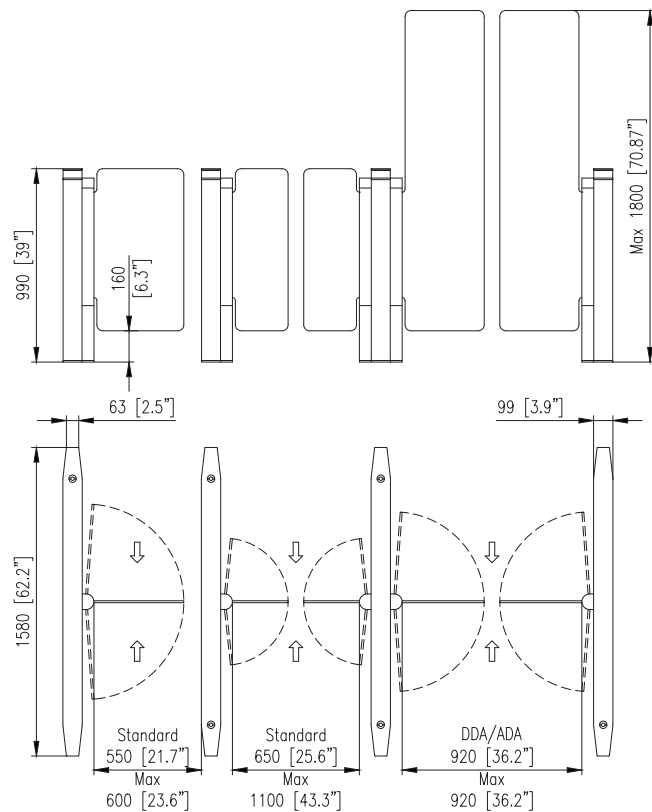



# EasyGate Elite / EliteS

## Type

Swing technology  
1 wing / 2 wings  
Round front

## Safety & Security Detection

- 30 pairs of IR sensors - Elite
- 20 pairs of IR sensors - EliteS
- Safety & Security levels
- Tailgating / Cross over detection

## Dimensions

Cabinet height	990 mm	38.98"
Cabinet length Elite	1 400 mm	55.12"
EliteS	1 070 mm	42.10"
Cabinet width	120 mm	4.72"
Barrier height standard	990 mm	38.98"
Barrier height max.	1 800 mm	70.87"
Passage width standard*	650 mm	25.59"
Passage width max.*	1 100 mm	43.31"
	<i>for height of glass wing up to 1 400 mm</i>	
	max 920 mm	36.22"
	<i>for height of glass wing up to 1 800 mm</i>	

## Special feature \*\*

Arc layout



EasyGate Elite / 990 mm



EasyGate Elite / 1 800 mm

\* For 2 wings type \*\* Optional



### Material and Colours

Frame	black RAL
Covers	brushed stainless steel
Top Lid	black glass
Barriers	tempered glass barrier panels (10 mm / 0.39")
Side infill panel	tempered glass panels (6 mm / 0.24")

### Operating Environment

Indoor

### Drive Mechanism

Fail-Safe  
MCBF 5 000 000

### Stand-by Power Consumption

22,6 W

### Emergency Mode

Open automatically in the exit direction

### Optional Accessories

- RFID reader bracket (flush mounted)
- Access Light / Edge Light / Wing Light
- WAV player
- Hinge capping
- Pressure sensing top
- RF remote control
- EasyTouch / TouchPanel / T-MON SW
- SuperCap (emergency power back-up)
- Alternative surface finishes / Optional top finishes
- Integration of LiftCall / Card collector / BarCode scanner
- Ramp LT

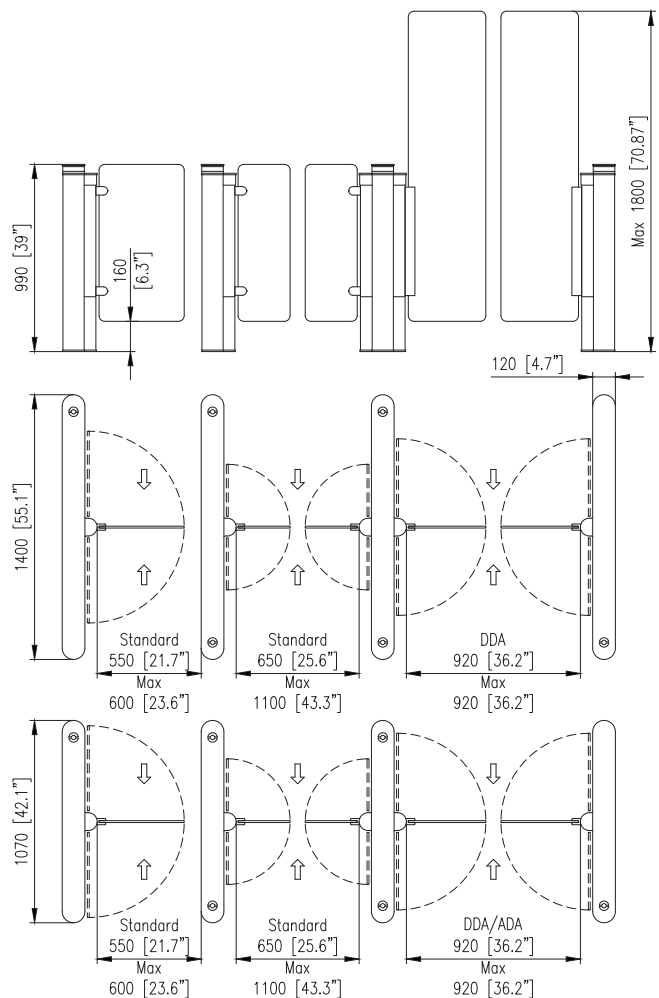



# EasyGate LC

## Type

Swing technology  
1 wing / 2 wings  
Square front

## Safety & Security Detection

- 36 pairs of IR sensors
- Safety & Security levels
- Tailgating / Cross over detection

## Dimensions

Cabinet height	990 mm	38.98"
Cabinet length	1 400 mm	55.12"
Cabinet width	150 mm	5.90"
Barrier height standard	990 mm	38.98"
Barrier height max.	1 800 mm	70.87"
Passage width standard*	650 mm	25.59"
Passage width max.*	1 100 mm	43.31"
	<i>for height of glass wing up to 1 400 mm</i>	
	<i>max 920 mm</i>	<i>36.22"</i>
	<i>for height of glass wing up to 1 800 mm</i>	

## Special features \*\*

Arc Layout  
Staggered / diagonal layout



EasyGate LC / 990 mm



EasyGate LC / 1 800 mm

\* For 2 wings type \*\* Optional





### Material and Colours

Covers	brushed stainless steel / black glass front and back
Top Lid	black glass
Barriers	tempered glass barrier panels (10 mm / 0.39")
Side infill panel	brushed stainless steel

### Operating Environment

Indoor

### Drive Mechanism

Fail-Safe  
MCBF 5 000 000

### Stand-by Power Consumption

22,6 W

### Emergency Mode

Open automatically in the exit direction

### Optional Accessories

- RFID reader bracket (flush mounted)
- Access Light / Lane Light / Wing Light
- Hinge capping
- WAV player
- Pressure sensing top
- RF remote control
- EasyTouch / TouchPanel / T-MON SW
- SuperCap (emergency power back-up)
- Alternative surface finishes / Optional top finishes
- Integration of LiftCall / Card collector / BarCode scanner
- Ramp LT

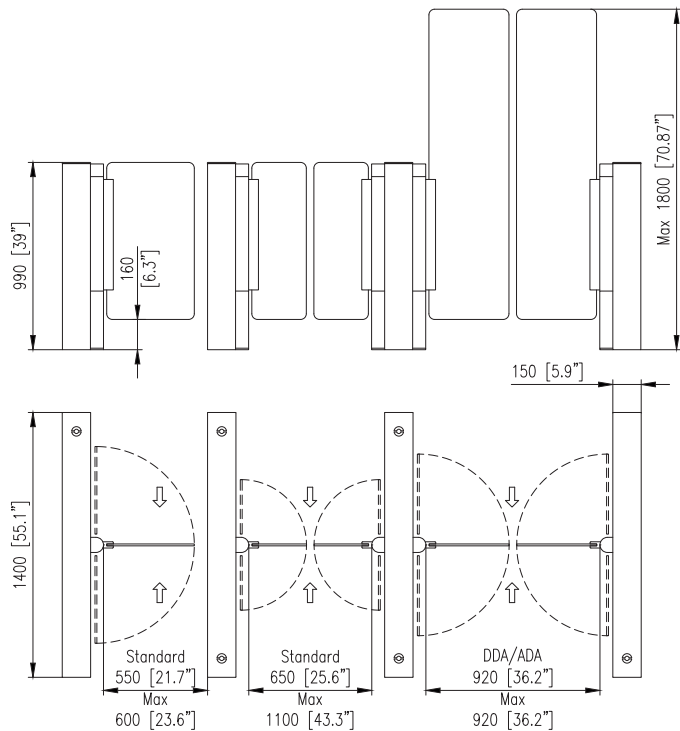



# EasyGate IM

## Type

Swing technology  
1 wing / 2 wings  
Square front

## Safety & Security Detection

- 36 pairs of IR sensors
- Safety & Security levels
- Tailgating / Cross over detection

## Dimensions

Cabinet height	995 mm	39.17"
Cabinet length	1 500 mm	59.10"
Cabinet width	210 mm	8.27"
Barrier height standard	1 200 mm	47.24"
Barrier height max.	1 800 mm	70.87"
Passage width standard*	650 mm	25.59"
Passage width max.*	1 050 mm	41.34"

## Special features \*\*

Heavy duty wing  
Arc layout



EasyGate IM / 1 200 mm



EasyGate IM / 1 800 mm

\* For 2 wings type \*\* Optional



### Material and Colours

Inner covers	brushed stainless steel
Cladding	corian
Barriers	tempered glass barrier panels (10 mm / 0.39")

### Operating Environment

Indoor

### Drive Mechanism

Magnetic Direct Drive motor with external tooth brake  
MCBF 20 000 000

### Stand-by Power Consumption

30,9 W

### Emergency Mode

Open automatically in the exit direction  
Pushthrough feature\*\*

### Optional Accessories

- RFID reader bracket (flush mounted)
- Access Light / Lane Light / Wing Light
- WAV player
- Hinge capping
- Pushthrough feature
- RF remote control
- EasyTouch / TouchPanel / T-MON SW
- SuperCap (emergency power back-up)
- Alternative surface finishes / Optional top finishes
- Integration of LiftCall / Card collector / BarCode scanner
- Ramp LT

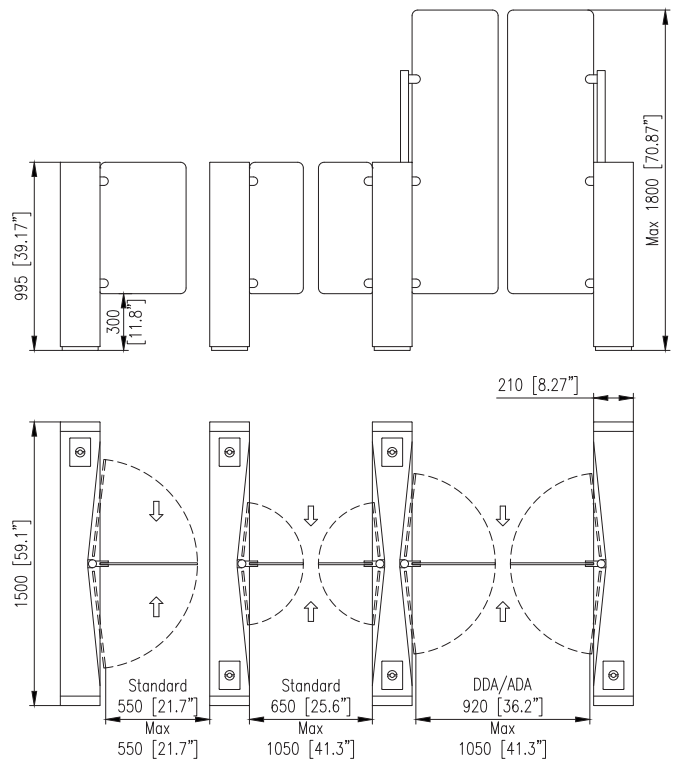



# EasyGate BV

## Type

Swing technology  
1 wing / 2 wings  
Square front

## Safety & Security Detection

- 36 pairs of IR sensors
- Safety & Security levels
- Tailgating / Cross over detection

## Dimensions

Cabinet height	990 mm	38.98"
Cabinet length	1 500 mm	59.06"
Cabinet width	200 mm	7.87"
Barrier height	800 mm	31.50"
Passage width standard*	650 mm	25.59"
Passage width max.*	1 000 mm	39.37"

## Special features\*\*

Arc layout  
Staggered / diagonal layout

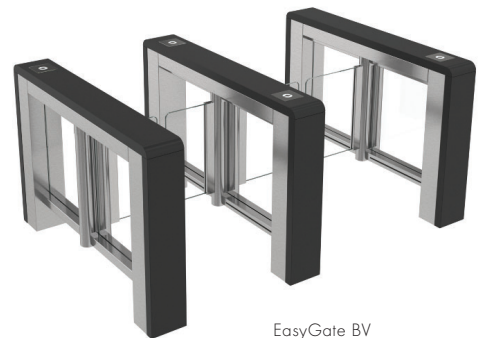

EasyGate BV



EasyGate BV

\* For 2 wings type \*\* Optional



### Material and Colours

Frame	brushed stainless steel
Cladding	corian
Barriers	tempered glass barrier panels (10 mm / 0.39")
Side infill panel	tempered glass panels (6 mm / 0.24")

### Operating Environment

Indoor

### Drive Mechanism

Fail-Safe

MCBF 5 000 000

### Stand-by Power Consumption

22,6 W

### Emergency Mode

Open automatically in the exit direction

### Optional Accessories

RFID reader bracket (flush mounted)

Access Light / Lane Light / Wing Light

WAV player

Hinge capping

RF remote control

EasyTouch / TouchPanel / T-MON SW

SuperCap (emergency power back-up)

Alternative surface finishes / Optional top finishes

Integration of LiftCall / Card collector / BarCode scanner

Ramp LT

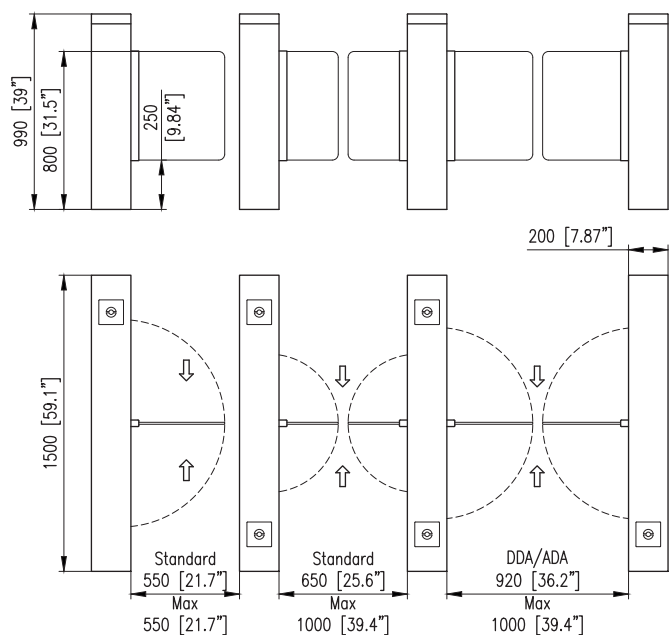

HERITAGE  
LANES



“  
THE SUNCORP WORKPLACE IS  
REPRESENTATIVE OF THE NEXT  
GENERATION OF WORKPLACE. THIS  
PLACE WILL BE TRULY QUEENSLAND.  
”

KIRSTI SIMPSON  
SUNCORP



EasyGate SPT-R

## EasyGate SPT-G / SPT-R

### Type

Swing technology  
1 wing / 2 wings  
SPT-G model - round front  
SPT-R model - square front

### Safety & Security Detection

- 36 pairs of IR sensors
- Safety & Security levels
- Tailgating / Cross over detection

### Dimensions

Cabinet height	975 mm	38.39"
Cabinet length	1 500 mm	59.06"
Cabinet width	180 mm	7.09"
Barrier height standard	1 200 mm	47.24"
Barrier height max.	1 800 mm	70.87"
Passage width standard*	650 mm	25.59"
Passage width max.*	1 050 mm	41.34"

### Special features\*\*

Wide passage lane	921 - 1 200 mm	36.26 - 47.24"
Extra wide passage lane	1 201 - 1 500 mm	47.28 - 59.05"
Heavy duty wing		
Arc layout		
Staggered / diagonal layout		



EasyGate SPT-G / 1 800 mm



EasyGate SPT-R / 1 200 mm

\* For 2 wings type \*\* Optional



EasyGate SPT-G

**Material and Colours**

Covers	brushed stainless steel
Top Lid	black glass
Barriers	tempered glass barrier panels (10 mm / 0.39")
Side infill panel	tempered glass panels (6 mm / 0.24")

**Operating Environment**

Indoor

**Drive Mechanism**

Magnetic Direct Drive motor with external tooth brake  
MCBF 20 000 000

**Stand-by Power Consumption**

30,9 W

**Emergency Mode**

Open automatically in the exit direction  
Pushthrough feature\*\*

**Optional Accessories**

- RFID reader bracket (flush mounted)
- Access Light / Lane Light / Edge Light / Wing Light / Passage Light
- WAV player
- Hinge capping
- Pushthrough feature / Pressure sensing top
- RF remote control
- EasyTouch / TouchPanel / T-MON SW / RF remote control
- SuperCap (emergency power back-up)
- Alternative surface finishes / Optional top finishes
- Integration of liftCall / Card collector / BarCode scanner

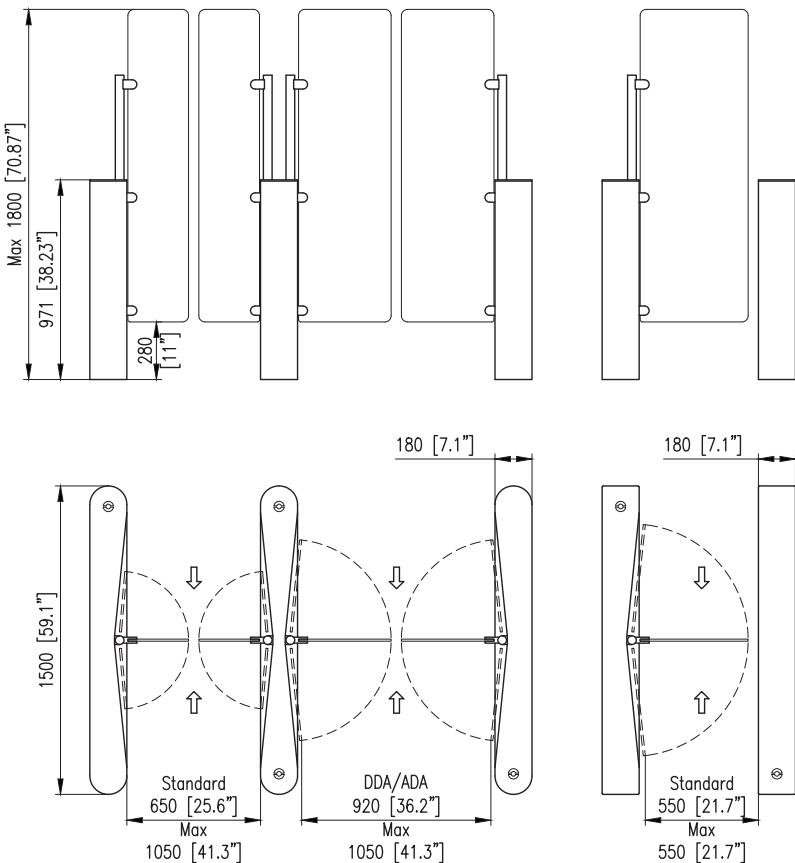



EasyGate SPD-R

## EasyGate SPD-G / SPD-R

### Type

Swing technology

1 wing / 2 wings

SPD-G model - round front

SPD-R model - square front

### Safety & Security Detection

- 36 pairs of IR sensors
- Safety & Security levels
- Tailgating / Cross over detection

### Dimensions

Cabinet height	975 mm	38.39"
Cabinet length	1 500 mm	59.06"
Cabinet width	180 mm	7.09"
Barrier height	850 mm	33.46"
Passage width standard*	650 mm	25.59"
Passage width max.*	1 150 mm	45.28"

### Special features\*\*

Wide passage lane	921 - 1 200 mm	36.26 - 47.24"
Extra wide passage lane	1 201 - 1 500 mm	47.28 - 59.05"
Heavy duty wing		
Arc layout		
Staggered / diagonal layout		

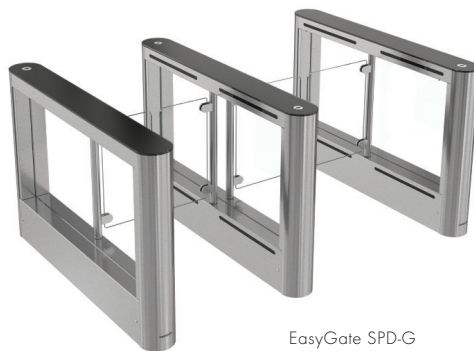

EasyGate SPD-G



EasyGate SPD-R

\* For 2 wings type \*\* Optional





EasyGate SPD.G

### Material and Colours

Covers	brushed stainless steel
Top lid	black glass
Barriers	tempered glass barrier panels (10 mm / 0.39")
Side infill panel	tempered glass panels (6 mm / 0.24")

### Operating Environment

Indoor

### Drive Mechanism

Magnetic Direct Drive motor with external tooth brake  
MCBF 20 000 000

### Stand-by Power Consumption

30,9 W

### Emergency Mode

Open automatically in the exit direction  
Pushthrough feature\*\*

### Optional Accessories

- RFID reader bracket (flush mounted)
- Access light / Lane light / Edge light / Wing light / Passage light
- WAV player
- Hinge capping
- Pushthrough feature / Pressure sensing top
- EasyTouch / TouchPanel / T-MON SW / RF remote control
- SuperCap (emergency power back-up)
- Alternative surface finishes / Optional top finishes
- Integration of LiftCall / Card collector / BarCode scanner
- Ramp LT

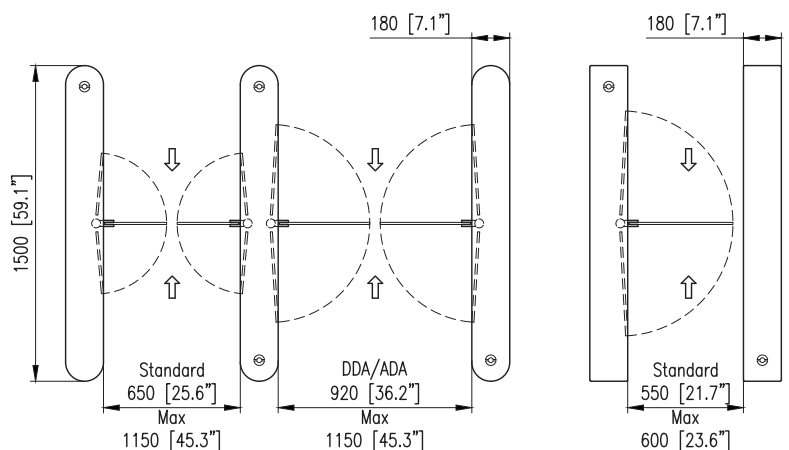
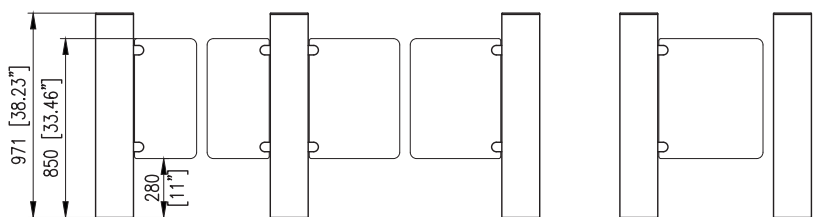



EasyGate SG

# EasyGate SG / SR 1000 & 1320

**Type**

- Swing technology
- 1 000 (length of cabinet in mm)
- 1 320 (length of cabinet in mm)
- 1 wing / 2 wings
- SG model - round front
- SR model - square front

**Safety & Security Detection**

- 24 pairs of IR sensors - version 1 000
- 36 pairs of IR sensors - version 1 320
- Safety & Security levels
- Tailgating / Cross over detection

**Dimensions**

Cabinet height	990 mm	38.98"
Cabinet length	1 000 mm 1 320 mm	39.37" 51.97"
Cabinet width	120 mm	4.72"
Barrier height	835 mm	32.87"
Passage width standard*	650 mm	25.59"
Passage width max.*	920 mm	36.22"

**Special features\*\***

- Arc layout
- Staggered / diagonal layout



EasyGate SG 1000



EasyGate SR 1000

\* For 2 wings type    \*\* Optional



EasyGate SR

### Material and Colours

Covers	brushed stainless steel
Top Lid	black glass
Barriers	tempered glass barrier panels (10 mm / 0.39")

### Operating Environment

Indoor

### Drive Mechanism

Fail-Safe

MCBF 5 000 000

### Stand-by Power Consumption

22,6 W

### Emergency Mode

Open automatically in the exit direction

### Optional Accessories

RFID reader bracket (flush mounted)

Access light / Lane light / Wing light

WAV player

Pressure sensing top

Hinge capping

RF remote control

EasyTouch / TouchPanel / T-MON SW

SuperCap (emergency power back-up)

Alternative surface finishes / Optional top finishes

Integration of BarCode scanner

Ramp LT

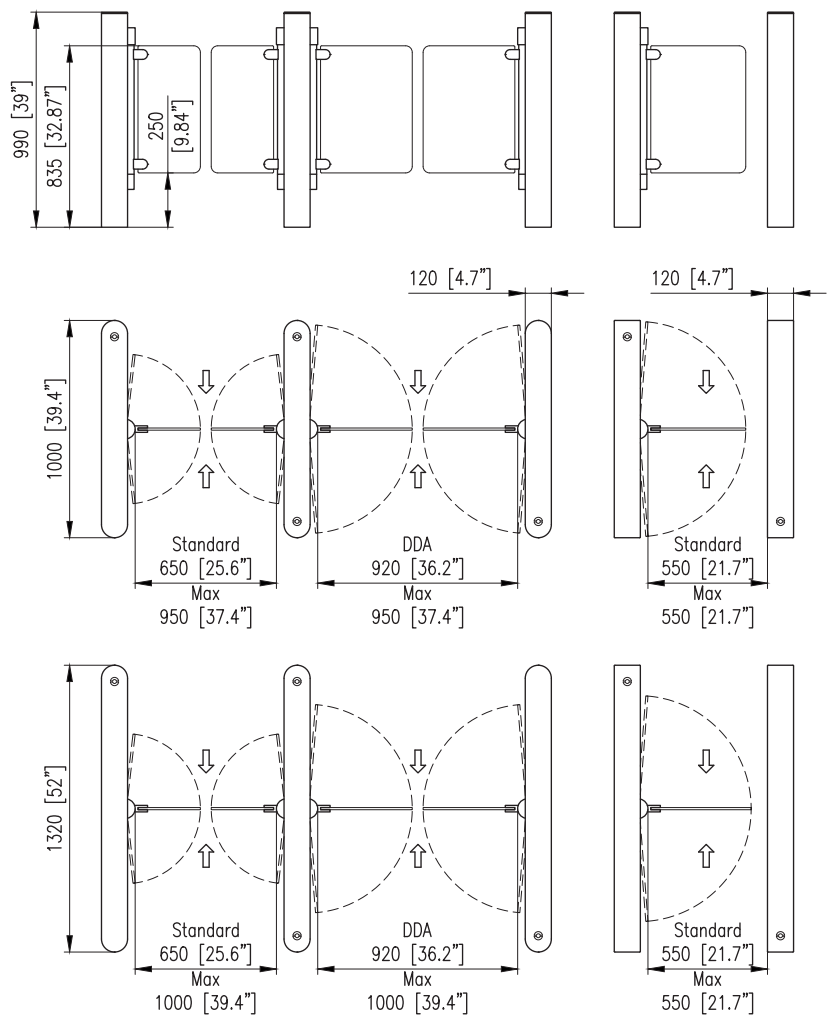



# EasyGate LG

## Type

Sliding technology  
 940 / 1 200 - 1 800 (height of glass barrier in mm)  
 2 wings  
 Round front

## Safety & Security Detection

- 42 pairs of IR sensors
- Safety & Security levels
- Tailgating / Cross over detection

## Dimensions

Cabinet height	990 mm	38.98"
Cabinet length	1 550 mm	61.02"
Cabinet width	330 mm	12.99"
DDA cabinet width	510 mm	20.08"
Barrier height	940 mm	37.01"
	1 200 - 1 800 mm	47.24" - 70.87"
Passage width standard	570 mm	22.44"
Passage width max.	920 mm	36.22"



EasyGate LG 1200 / 1800



EasyGate LG 940



### Material and Colours

Covers	brushed stainless steel
Top Lid	brushed stainless steel
Barriers	tempered glass barrier panels (8 mm / 0.31")

### Operating Environment

Indoor

### Drive Mechanism

Magnetic Direct Drive motor  
MCBF 20 000 000

### Stand-by Power Consumption

83,4 W

### Emergency Mode

Open automatically

### Optional Accessories

- RFID reader bracket (flush mounted)
- Access Light / Lane Light / Wing Light (only for 940 model)
- WAV player
- Pressure sensing top
- USB convertor / Ethernet convertor
- RF remote control
- EasyTouch / TouchPanel / T-MON SW
- SuperCap (emergency power back-up)
- Alternative surface finishes / Optional top finishes
- Integration of LiftCall / Card collector / BarCode scanner
- Ramp LT

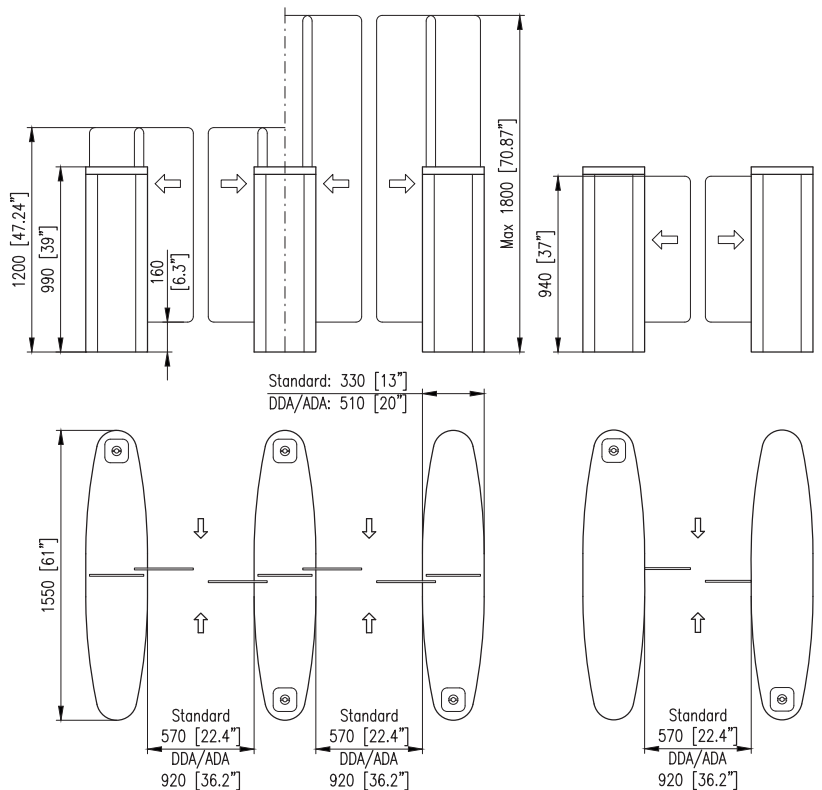



# EasyGate BG

## Type

Sliding technology  
 950 (height of glass barrier in mm)  
 2 wings

## Safety & Security Detection

- 42 pairs of IR sensors
- Safety & Security levels
- Tailgating / Cross over detection

## Dimensions

Cabinet height	990 mm	38.98"
Cabinet length	1 326 mm	52.21"
Cabinet width	330 mm	12.99"
Barrier height	950 mm	37.40"
Passage width	570 mm	22.44"



EasyGate BG



### Material and Colours

Covers	brushed stainless steel
Top Lid	black glass
Barriers	tempered glass barrier panels (8 mm / 0.31")

### Operating Environment

Indoor

### Drive Mechanism

Magnetic Direct Drive motor with external tooth brake  
MCBF 20 000 000

### Stand-by Power Consumption

83,4 W

### Emergency Mode

Open automatically

### Optional Accessories

- RFID reader bracket (flush mounted)
- Access Light / Lane Light / Wing light
- WAV player
- Pressure sensing top
- USB convertor / Ethernet convertor
- RF remote control
- EasyTouch / TouchPanel / T-MON SW
- SuperCap (emergency power back-up)
- Alternative surface finishes / Optional top finishes
- Integration of LiftCall / Card collector / BarCode scanner
- Ramp LT

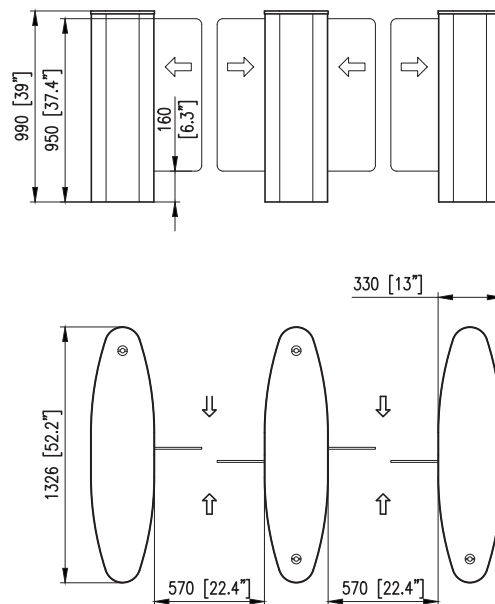



EasyGate LX 1800

# EasyGate LX / LH

**Type**

Sliding technology  
 940 / 1 200 - 1 800 (height of glass barrier in mm)  
 2 wings  
 LX model - round front  
 LH model - square front

**Safety & Security Detection**

- 40 pairs of IR sensors
- Safety & Security levels
- Tailgating / Cross over detection

**Dimensions**

Cabinet height	990 mm	38.98"
Cabinet length	1 700 mm	66.93"
Cabinet width	320 mm	12.60"
DDA cabinet width	500 mm	19.68"
Barrier height	940 mm	37.01"
	1 200 - 1 800 mm	47.24 - 70.87"
Passage width standard	570 mm	22.44"
Passage width max.	920 mm	36.22"



EasyGate LX 1200



EasyGate LH 940





EasyGate LH 940

**Material and Colours**

Covers	brushed stainless steel
Top Lid	brushed stainless steel with black top ends
Barriers	tempered glass barrier panels (8 mm / 0.31")

**Operating Environment**

Indoor

**Drive Mechanism**

Fail-Safe

**Emergency Mode**

Open automatically

**Optional Accessories**

- RFID reader bracket (flush mounted)
- Access Light / Lane Light / Wing Light (only for 940 model)
- WAV player
- Outdoor package
- USB convertor / Ethernet convertor
- RF remote control
- EasyTouch / TouchPanel / T-MON SW
- SuperCap (emergency power back-up)
- Alternative surface finishes / Optional top finishes
- Integration of liftCall / Card collector / BarCode scanner
- Ramp LT

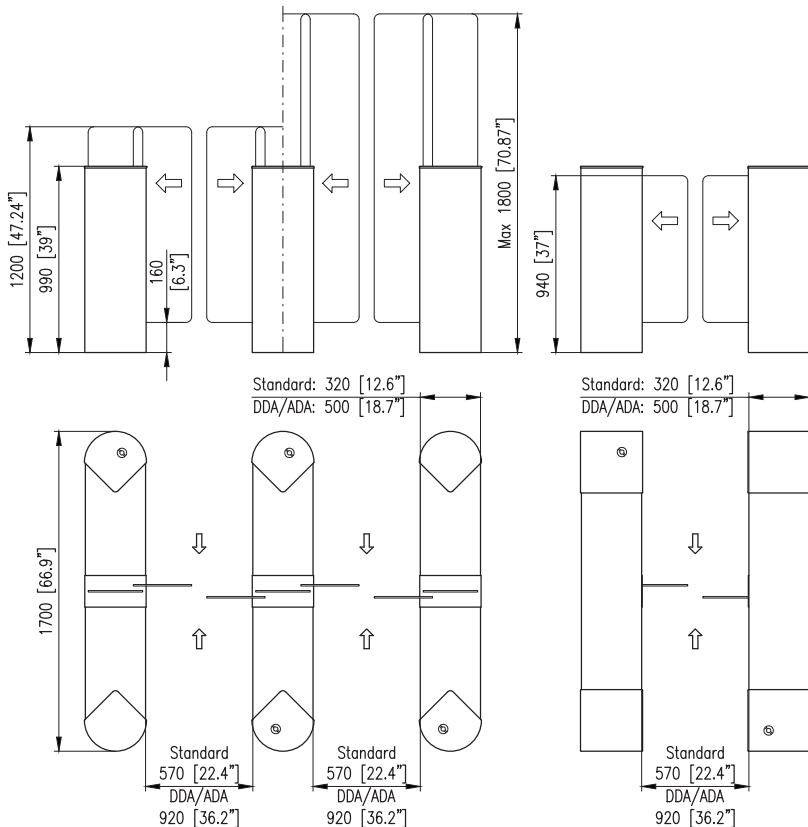



## EasyGate FL / FH

### Type

Sliding technology

2 wings

FL model - round front

FH model - square front

### Safety & Security Detection

- 40 pairs of IR sensors
- Safety & Security levels
- Tailgating / Cross over detection

### Dimensions

Cabinet height	990 mm	38.98"
Cabinet length	1 700 mm	66.93"
Cabinet width	320 mm	12.60"
DDA cabinet width	510 mm	20.08"
Barrier height	940 mm	37.01"
Passage width standard	570 mm	22.44"
Passage width max.	920 mm	36.22"

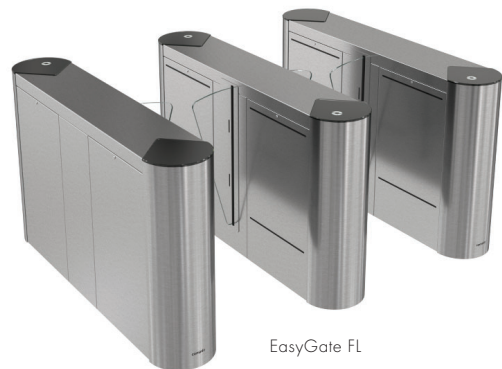

EasyGate FL



EasyGate FH



EasyGate FL

**Material and Colours**

Covers	brushed stainless steel
Top Lid	brushed stainless steel with black top ends
Barriers	tempered glass barrier panels (10 mm / 0.39")

**Operating Environment**

Indoor

**Drive Mechanism**

Fail-Safe

**Emergency Mode**

Open automatically

**Optional Accessories**

- RFID reader bracket (flush mounted)
- Access Light / Lane Light / Wing light
- WAV player
- Outdoor package
- USB convertor / Ethernet convertor
- RF remote control
- EasyTouch / TouchPanel / T-MON SW
- SuperCap (emergency power back-up)
- Alternative surface finishes / Optional top finishes
- Integration of liftCall / Card collector / BarCode scanner
- Ramp LT

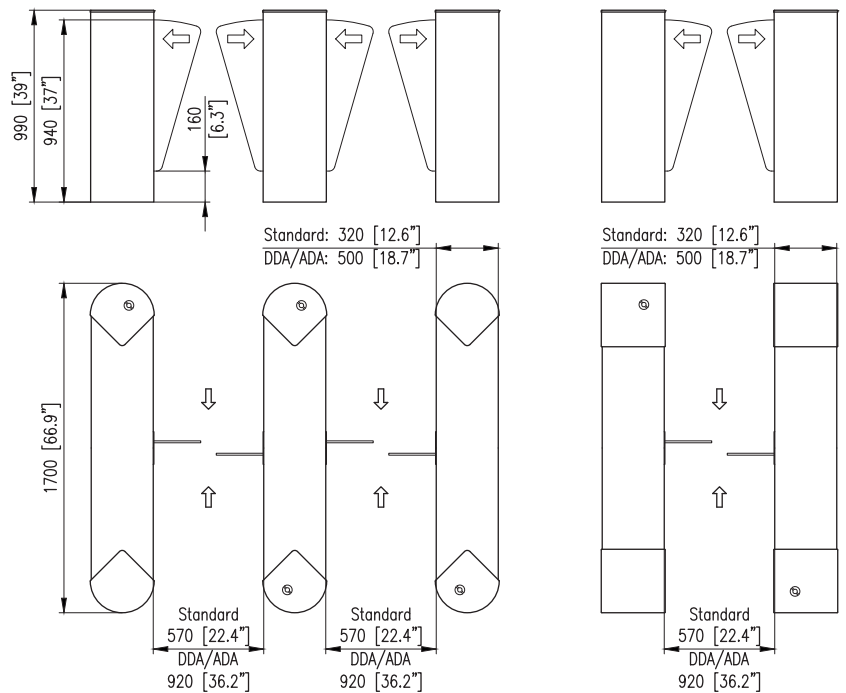



# EasyGate SPT-G Outdoor / SPT-R Outdoor

## Type

Swing technology developed to withstand harsh outdoor conditions - IP 53

1 wing / 2 wings

G model - round front

R model - square front

## Safety & Security Detection

- 36 pairs of IR sensors
- Safety & Security levels
- Tailgating / Cross over detection

## Dimensions

Cabinet height	990 mm	39"
Cabinet length	1 500 mm	59.06"
Cabinet width	210 mm	8.30"
Barrier height standard	895 mm	35.23"
Barrier height max.	1 400 - 1 800 mm	70.87"
Passage width standard*	650 mm	25.59"
Passage width max.*	1 000 mm	39.37"



EasyGate SPT-R Outdoor



EasyGate SPT-G Outdoor

\* For 2 wings type



### Material and Colours

Covers	brushed stainless steel
Top lid	black glass
Barriers	tempered glass barrier panels (10 mm / 0.39")
Side infill panel	tempered glass panels (6 mm (0.24"))

### Operating Environment

Outdoor - IP 53

### Drive Mechanism

Magnetic Direct Drive motor with external tooth brake  
MCBF 20 000 000

### Stand-by Power Consumption

30,9 W\*\*

### Emergency Mode

Open automatically in the exit direction  
Pushthrough feature\*\*\*

### Optional Accessories

- RFID reader bracket (flush mounted)
- Access light / Lane light / Wing light
- WAV player
- Hinge capping
- Pushthrough feature / Pressure sensing top
- RF remote control
- EasyTouch / TouchPanel / T-MON SW
- SuperCap (emergency power back-up)
- Alternative surface finishes
- Integration of Barcode and QR code scanner
- Ramp LT

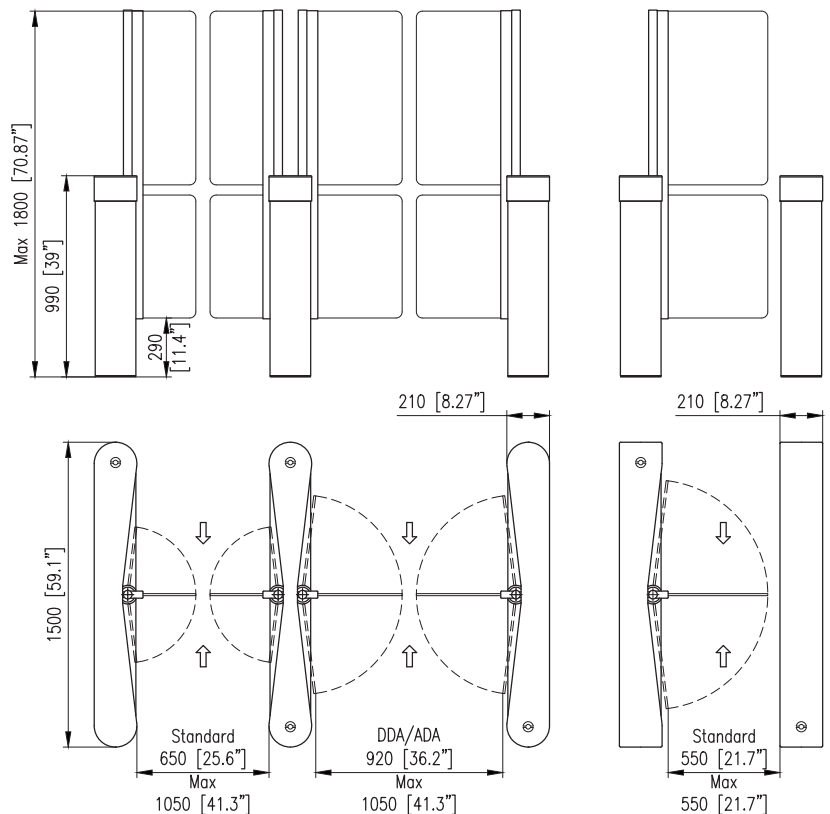

\*\* without heating \*\*\* Optional



# EasyGate WN

## Type

Swing technology  
1 wing / 2 wings  
Square front

## Safety & Security Detection

- 8 pairs of IR sensors
- Safety & Security levels
- Tailgating / Cross over detection

## Dimensions

Cabinet height	1 070 mm	42.13"
Cabinet length	2 000 mm	78.74"
Cabinet width	210 mm	8.27"
Barrier height	900 mm	35.43"
Passage width standard*	650 mm	25.59"
Passage width max.*	1 200 mm	47.24"



EasyGate WN



EasyGate WN

\* For 2 wings type



### Material and Colours

Frame	brushed stainless steel
Top Lid	brushed stainless steel
Barriers	brushed stainless steel tube wing

### Operating Environment

Indoor / Outdoor / Extreme weather conditions (up to -40°C)\*\*

### Drive Mechanism

Fail-Safe  
MCBF 5 000 000

### Stand-by Power Consumption

22,6 W

### Emergency Mode

Open automatically in the exit direction

### Optional Accessories

- RFID reader bracket (flush mounted)
- Access Light / Lane Light
- WAV player
- Outdoor package / Extreme outdoor package
- RF remote control
- EasyTouch / TouchPanel / T-MON SW
- Alternative surface finishes
- Induction loop system for detection of bicycles and scooters
- Ramp LT

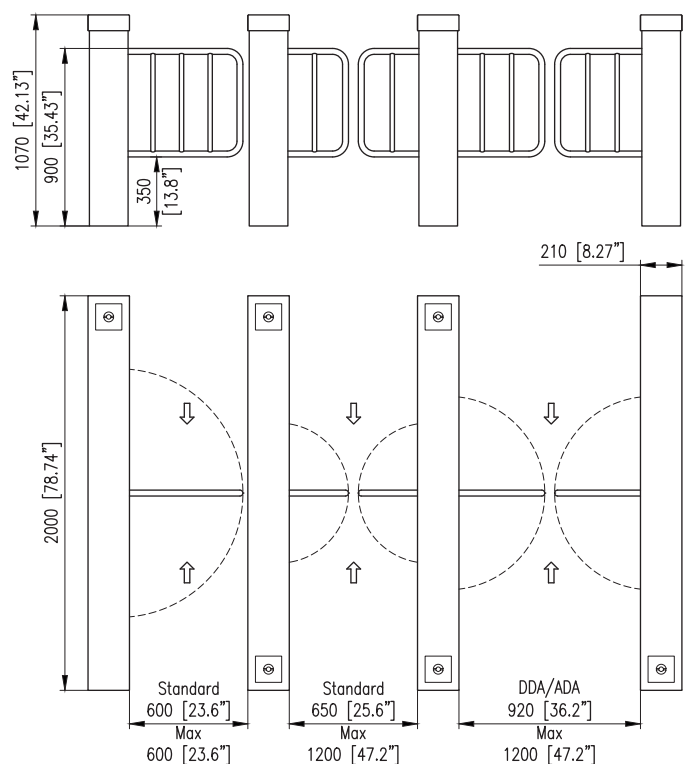

\*\* Optional



## EasyGate SPA (Speed Gate for Paid Access)

### Type

Swing technology  
1 wing / 2 wings\*  
Square front

### Safety & Security Detection

- 30 pairs of IR sensors
- Safety & Security levels
- Tailgating / Cross over detection

### Dimensions

Cabinet height	1 400 mm	55.12"
Cabinet length	1 200 mm	47.24"
Cabinet width	180 mm	7.09"
Barrier height	1 400 mm	55.12"
Passage width standard	550 mm	21.65"
Passage width max.	920 mm	36.22"



EasyGate SPA ECO



EasyGate SPA Premium

\* EasyGate SPA ECO / ECO+ feature master cabinet and sensor wall, respectively railings with sensors. EasyGate SPA Premium features master cabinet and side cabinet.





### Material and Colours

Frame	brushed stainless steel
Barriers	tempered glass barrier panels (10 mm / 0.39")
Side infill panel	tempered glass panels (8 mm / 0.31")

### Operating Environment

Indoor

### Drive Mechanism

Magnetic Direct Drive motor with external tooth brake  
MCBF 20 000 000

### Stand-by Power Consumption

29,3 W

### Emergency Mode

Open automatically in the exit direction  
Pushthrough feature

### Optional Accessories

- RFID reader bracket (flush mounted)
- Lane Light / Wing light/ Coin input Light
- WAV player
- Hinge capping
- Pushthrough
- EasyTouch / TouchPanel / T-MON SW / RF remote control
- SuperCap (emergency power back-up)
- Emergency push button
- Alternative surface finishes
- Integration of Cashless payment system (Receipt & coupon thermal printer)
- Ramp LT

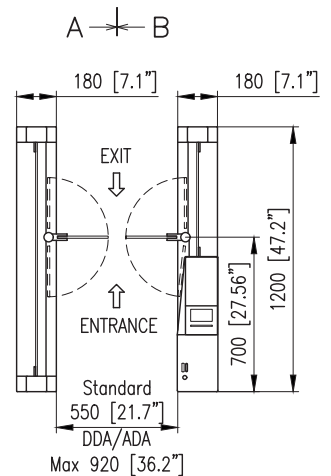
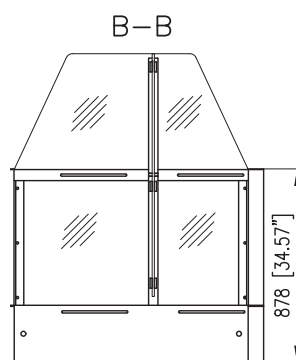
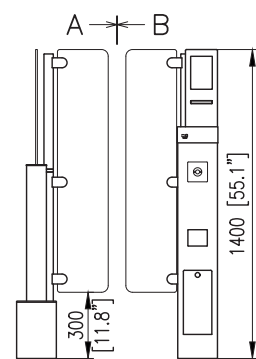
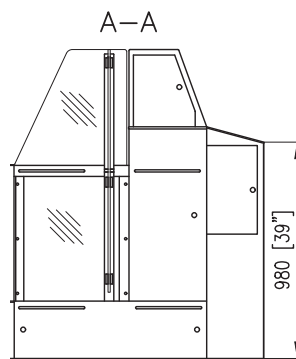



## EasyGate SBG (Self Boarding Gate for Airports)

### Type

Swing technology  
2 wings  
Square front

### Safety & Security Detection

- SITA Protocol Certified
- Boarding pass scanner
- 36 pairs of IR sensors
- Safety & Security levels
- Tailgating / Cross over detection

### Dimensions

Cabinet height	990 mm	39"
Cabinet length	1 500 mm	59.06"
Cabinet width	210 mm	8.3"
Barrier height	990 mm	39"
Passage width standard	650 mm	25.6"
Passage width max.	1 050 mm	41.3"

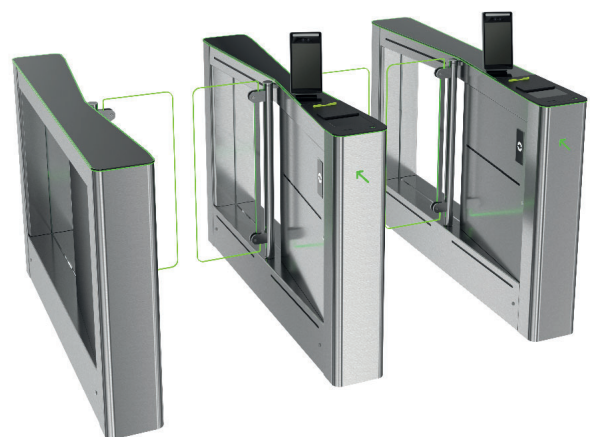

EasyGate SBG



### Material and Colours

Covers	brushed stainless steel
Top Lid	black glass
Barriers	tempered glass barrier panels (10 mm / 0.39")
Side infill panel	tempered laminated glass panels (10 mm / 0.39")

### Operating Environment

Indoor

### Drive Mechanism

Magnetic Direct Drive motor with external tooth brake  
MCBF 20 000 000

### Stand-by Power Consumption

30,9 W

### Emergency Mode

Open automatically in the exit direction

### Optional Accessories

Boarding pass reader, Passport reader  
Thermal printer  
Biometric device, Thermal infrared camera  
RFID reader  
Lane Light / Wing Light / Passage Light  
WAV player  
EasyTouch / TouchPanel / T-MON SW  
SuperCap (emergency power back-up)  
Emergency push button  
Alternative surface finishes  
Ramp LT

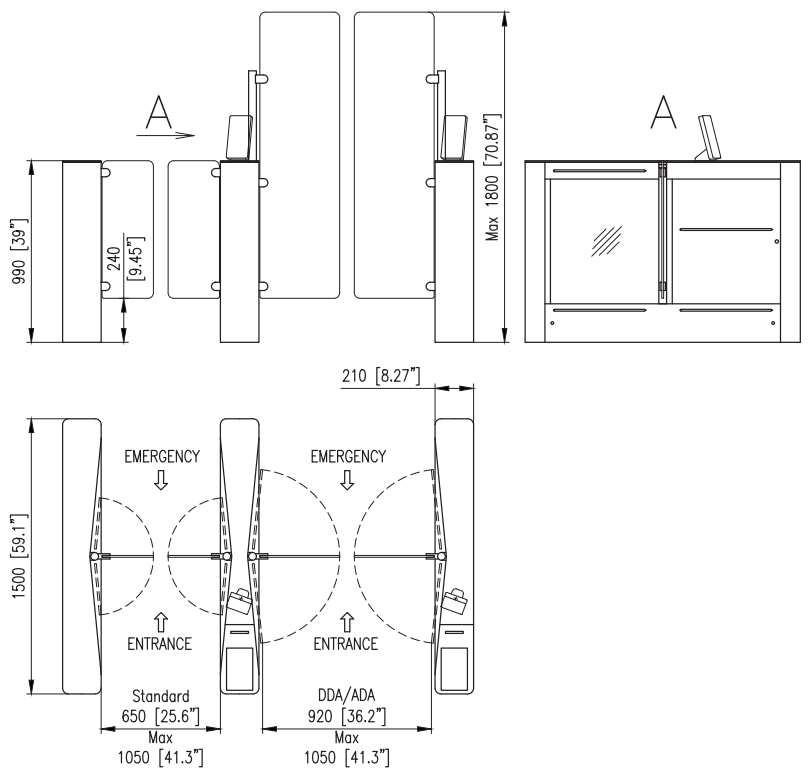



## e-Gate (Automated Border Control)

### Type

Automated Border Control  
 Interlock technology (4 wings glass barriers)  
 Swing opening of glass barriers  
 Custom integration of any 3rd party equipment

### Safety & Security Detection

- 78 pairs of IR sensors per passage lane
- Safety & Security levels
- Tailgating / Crossover detection
- Leftover luggage detection
- 7" LCD Screen

### Dimensions

Cabinet height	990 mm	38.98"
Cabinet length	2870 mm	112.99"
Cabinet width	240 mm	9.45"
Barrier height	1200-1800 mm	47.27-70.87"
Passage width standard	650 mm	25.6"
Passage width max.	1 050 mm	41.3"
Facial recognition totem height	1 950 mm	76.77"



E-gate



### Material and Colours

Covers	brushed stainless steel
Cabinet base	stainless steel black RAL
Barriers	tempered glass barrier panels (10 mm / 0.39")
Side infill panel	tempered laminated glass panels (10 mm / 0.39")

### Operating Environment

Indoor

### Drive Mechanism

Magnetic Direct Drive motor with external tooth brake  
MCBF 20 000 000

### Emergency Mode

Dedicated emergency (Fire alarm) input for automatic opening of wing barrier when Emergency signal is activated

### Optional Accessories

Smart card reader for ID card, Passport reader  
Biometric device, Thermal infrared camera  
RFID reader  
BarCode scanner  
Pole for CCTV camera  
Lane light  
WAV player  
Wing light / Hinge capping  
Pushthrough feature  
EasyTouch / TouchPanel / T-MON SW  
SuperCap (emergency power back-up)  
Integration for industrial PC with brackets  
Ramp LT

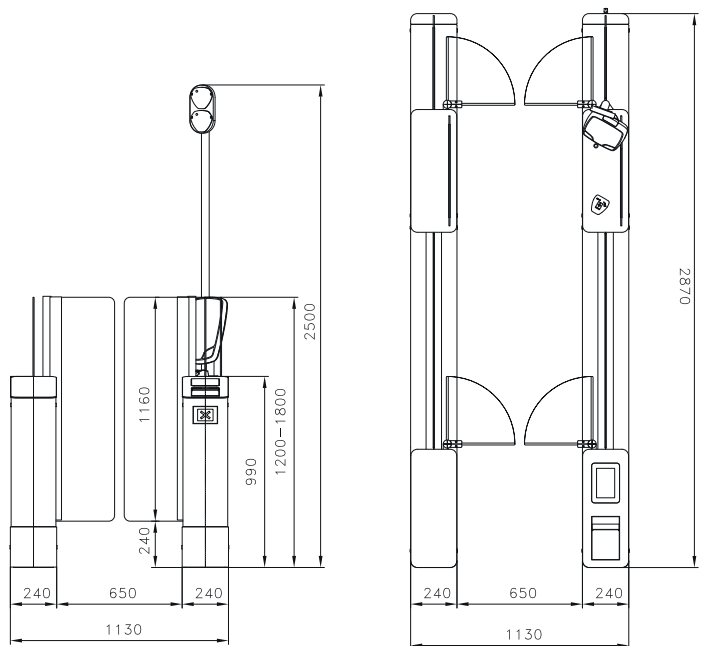



EasyGate SPT-G Bike

## EasyGate SPT-G Bike / SPT-R Bike

### Type

Swing technology  
2 wings  
G model - round front  
R model - square front

### Safety & Security Detection

- 36 pairs of IR sensors
- Induction loop
- Safety & Security levels
- Tailgating / Cross over detection

### Dimensions

Cabinet height	975 mm	38.39"
Cabinet length	2 000 mm	78.74"
Cabinet width	180 mm	7.09"
Barrier height standard	1 200 mm	47.24"
Barrier height max.	1 800 mm	70.87"
Passage width standard	900 mm	35.43"
Passage width max.	920 mm	36.22"

### Special features

Z-Shape tempered glass barrier panels  
Heavy duty wings\*  
Cabinet extension for mass transit terminals\*



EasyGate SPT-G Bike / 1 800 mm



EasyGate SPT-R Bike / 1 200 mm

\*Optional



EasyGate SPT-G Bike

**Material and Colours**

Covers	brushed stainless steel
Top lid	black glass
Barriers	Z-Shape tempered glass barrier panels (10 mm / 0.39")
Side infill panel	tempered glass panels (6 mm / 0.24")

**Operating Environment**

Indoor

**Drive Mechanism**

Magnetic Direct Drive motor with external tooth brake  
MCBF 20 000 000

**Emergency Mode**

Open automatically in the exit direction  
Pushthrough feature\*

**Optional Accessories**

- RFID reader bracket (flush mounted)
- Access light / Lane light / Wing Light
- WAV player
- Hinge capping
- Pushthrough feature / Pressure sensing top
- EasyTouch / TouchPanel / T-MON SW / RF remote control
- SuperCap (emergency power back-up)
- Alternative surface finishes / Optional top finishes
- Integration of liftCall / Card collector / BarCode scanner
- Ramp LT / Bike
- Loop-to-concrete package

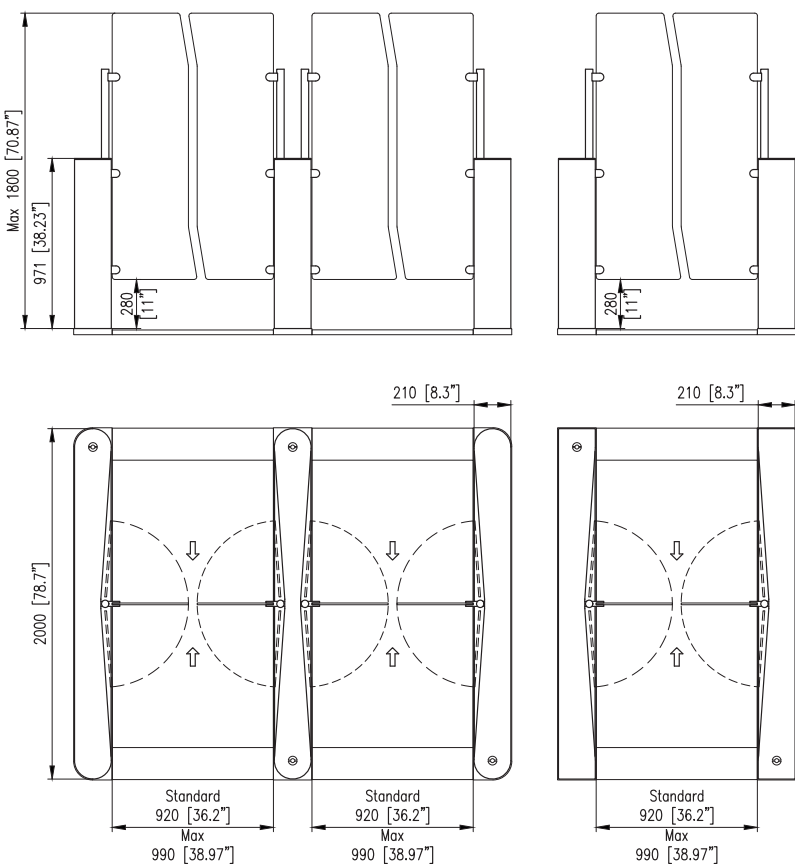



# EasyGate SPT-G / SPT-R Bike Outdoor

## Type

Swing technology  
 2 wings  
 G model - round front  
 R model - square front

## Safety & Security Detection

- 36 pairs of IR sensors
- Induction loop
- Safety & Security levels
- Tailgating / Cross over detection

## Dimensions

Cabinet height	975 mm	38.38"
Cabinet length	2 000 mm	78.74"
Cabinet width	210 mm	8.30"
Barrier height standard	1 200 mm	47.24"
Barrier height max.	1 800 mm	70.87"
Passage width standard	900 mm	35.43"
Passage width max.	920 mm	36.22"

## Special features

Z-Shape tempered glass barrier panels  
 Heavy duty wings\*  
 Cabinet extension for mass transit terminals\*



EasyGate SPT-R Bike Outdoor



EasyGate SPT-G Bike Outdoor

\*Optional



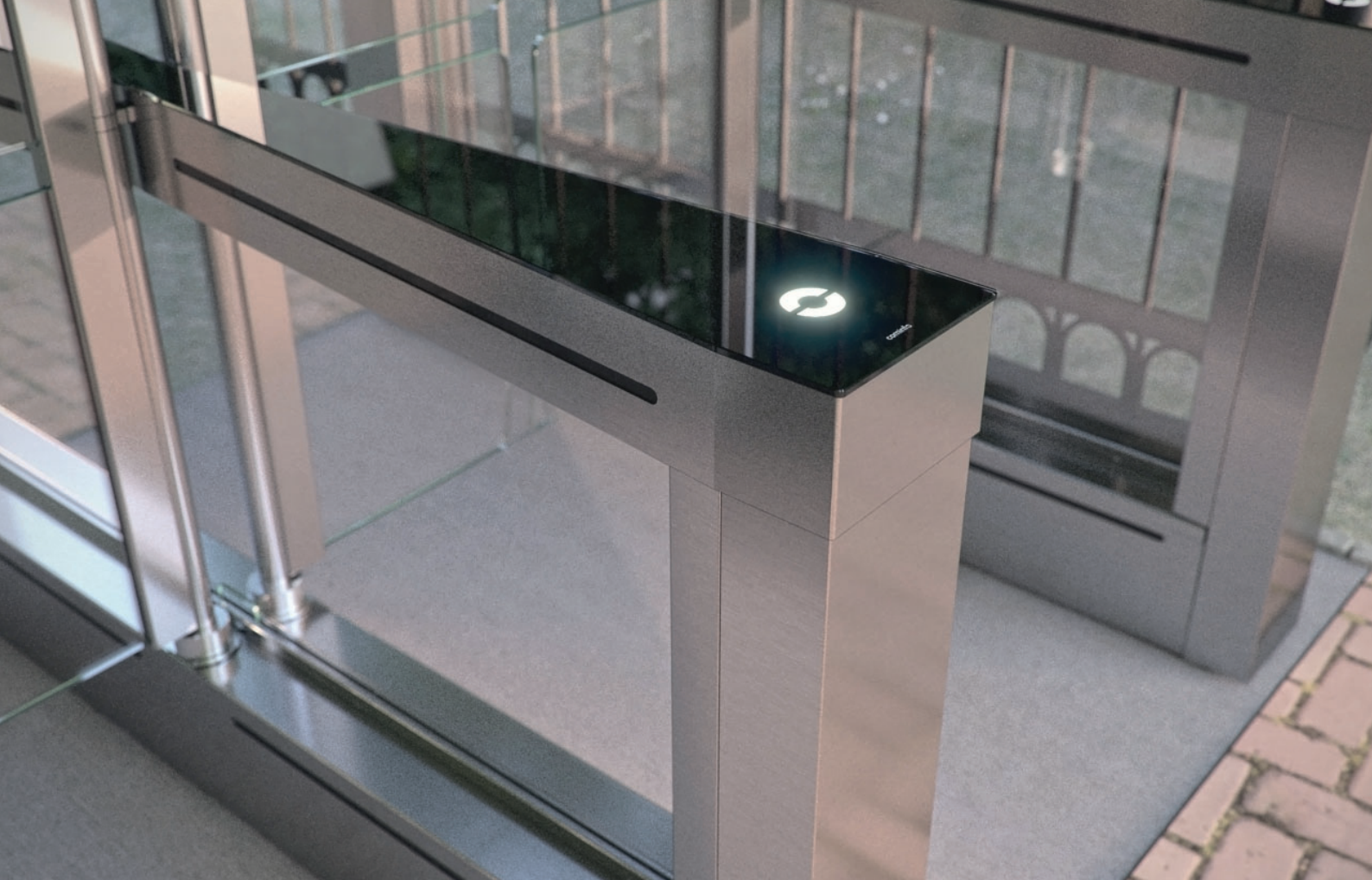

### Material and Colours

Covers	brushed stainless steel
Top lid	black glass
Barriers	Z-Shape tempered glass barrier panels (10 mm / 0.39")
Side infill panel	tempered glass panels (6 mm (0.24"))

### Operating Environment

Outdoor - IP 53

### Drive Mechanism

Magnetic Direct Drive motor with external tooth brake  
MCBF 20 000 000

### Emergency Mode

Open automatically in the exit direction  
Pushthrough feature

### Optional Accessories

- RFID reader bracket (flush mounted)
- Access Light / Lane Light / Wing Light
- WAV player
- Hinge capping
- Pushthrough feature / Pressure sensing top
- RF remote control
- EasyTouch / TouchPanel / T-MON SW
- SuperCap (emergency power back-up)
- Alternative surface finishes / Optional top finishes
- Ramp LT / Bike
- Loop-to-concrete package

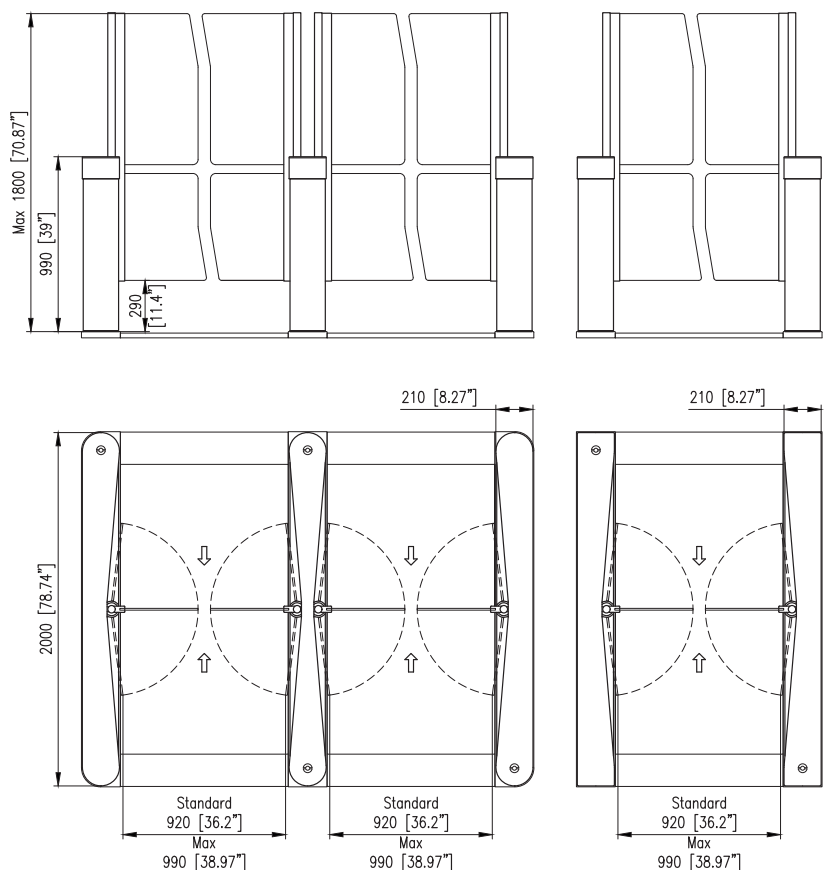



## Interlock Gate (High Security Double Speed Gate)

### Type

Swing technology  
 4 wings  
 G model - round front  
 R model - square front

### Safety & Security Detection

- 75 pairs of IR sensors
- Safety & Security levels
- Tailgating / Cross over detection

### Dimensions

Cabinet height	975 mm	38.39"
Cabinet length	2 900 mm	114.77"
Cabinet width	180 mm	7.09"
Barrier height standard	1 200 mm	47.24"
Barrier height max.	1 800 mm	70.87"
Passage width standard	650 mm	25.59"
Passage width max.	1 050 mm	41.34"

### Special features\*

Wide passage lane 921 - 1 200 mm 36.26" - 47.24"  
 Extra wide passage lane 1 201 - 1 500 mm 47.28" - 59.05"  
 Heavy duty wing

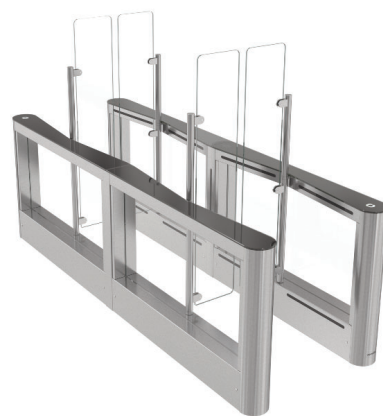

Interlock gate

\* Optional accessories



### Material and Colours

Covers	brushed stainless steel
Top Lid	black glass
Barriers	tempered glass barrier panels (10 mm / 0.39")
Side infill panel	tempered glass panels (6 mm / 0.24")

### Operating Environment

Indoor

### Drive Mechanism

Magnetic Direct Drive motor with external tooth brake  
MCBF 20 000 000

### Emergency Mode

Open automatically in the exit direction  
Pushthrough feature\*

### Optional Accessories

RFID reader bracket (flush mounted)  
Access light / Lane light / Edge light / Wing light  
WAV player  
Hinge capping  
Pushthrough feature / Pressure sensing top  
EasyTouch / TouchPanel / T-MON SW  
SuperCap (emergency power back-up)  
Alternative surface finishes / Optional top finishes  
Integration of liftCall / Card collector / BarCode scanner  
Ramp LT

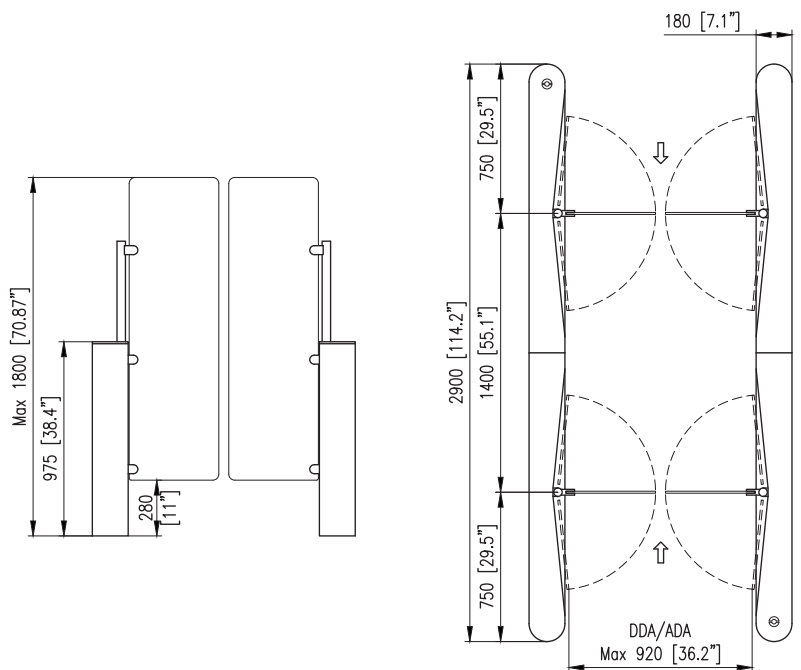

\* Optional accessories

# EasyGate - Swing Technology Overview



Type	Superb	Elite	EliteS	LC
Shape of cabinet - rounded / square	- / •	• / -	• / -	- / •
Available models - 1 wing / 2 wings	• / •	• / •	• / •	• / •
<b>Dimensions</b>				
Cabinet Height in mm (inches)	990 / 38.98"	990 / 38.98"	990 / 38.98"	990 / 38.98"
Cabinet Length in mm (inches)	1 580 / 62.20"	1 400 / 55.12"	1 070 / 42.1"	1 400 / 55.12"
Cabinet Width in mm (inches)	99 / 3.90"	120 / 4.72"	120 / 4.72"	150 / 5.90"
Glass wing barrier height in mm (inches)	up to 1 800 / 70.87"	up to 1 800 / 70.87"	up to 1 800 / 70.87"	up to 1 800 / 70.87"
Glass wing barrier thickness in mm (inches)	10 / 0.39"	10 / 0.39"	10 / 0.39"	10 / 0.39"
DDA (ADA) Compliant	•	•	•	•
<b>Standard Material</b>				
Stainless steel cabinet (AISI 304) / Special material	• / -	• / -	• / -	• / -
Stainless steel top lid (AISI 304) / Glass top Lid / Corian	- / • / -	- / • / -	- / • / -	- / • / -
<b>Safety Features</b>				
Emergency (Fire Alarm) input	•	•	•	•
Tailgating / Cross over	• / •	• / •	• / •	• / •
Number of sensor pairs (Transmitter / Receiver)	24	30	20	36
Pushthrough* / Pressure Sensing Top*	- / -	- / -	- / -	- / -
Induction loop system for detection of bicycles and scooters	-	-	-	-
Fail-Safe motor [1] / MDD motor	• / -	• / -	• / -	• / -
Safety & Security mode (5 settings)	•	•	•	•
Barrier opening time (s)	0.7	0.7	0.7	0.7
<b>Communication Interface</b>				
Relay Inputs / Outputs	• / •	• / •	• / •	• / •
RS485 / USB* / Ethernet*	• / • / •	• / • / •	• / • / •	• / • / •
<b>Operating Environment</b>				
Indoor / Outdoor covered <sup>[7]</sup> / Outdoor uncovered	• / - / -	• / - / -	• / - / -	• / - / -
Extreme weather condition	-	-	-	-
<b>Optional Features</b>				
Integrated RFID reader bracket - flush mounted	•	•	•	•
Access Light / Lane Light / Edge Light	• / • / •	• / • / •	• / • / •	• / • / -
Passage Light / Wing Light / WAV Player	• / - / •	- / • / •	- / • / •	- / • / •
Identification or Ticket Terminals	-	•	•	•
Implementation of: Lift controller / Visitor Card collector / BarCode scanner	• / • / •	- / • / -	- / • / -	• / • / •
<b>Optional Remote Control Systems</b>				
Remote control (EasyTouch, TouchPanel)	•	•	•	•
TMON software application (remote control from any PC) / Passage Scheduler (automatic planner)	• / •	• / •	• / •	• / •
<b>Optional Power Supply Input</b>				
13.8V DC / 230V AC or 110V AC	• / •	• / •	• / •	• / •
SuperCap	•	•	•	•
<b>Optional Finishes</b>				
Custom surface finish	-	•	•	-
Custom Top Lid material / Custom cladding material	- / -	• / -	• / -	- / -
<b>Optional Mounting Accessories</b>				
Ramp LT / Mounting console	• / •	• / •	• / •	• / •

[1] Free-to-move without power  
• = Available

[2] Stainless steel tube wing  
\* = Not available

[3] Only with stainless steel Top Lid  
\* Optional accessories

[4] Only for 940 mm high glass wing  
[6] Different dimensions of cabinet

[5] Only for square cabinet  
[7] The roof needs to overlap the turnstile sufficiently



- / •	- / •	• / •	• / •	• / •	• / •
• / •	• / •	• / •	• / •	• / •	• / •
995 / 39.17"	990 / 38.98"	975 / 38.39"	975 / 38.39"	990 / 38.98"	990 / 38.98"
1 500 / 59.10"	1 500 / 59.10"	1 500 / 59.06"	1 500 / 59.06"	1 000 / 39.37"	1 320 / 51.97"
210 / 8.27"	200 / 7.87"	180 / 7.09"	180 / 7.09"	120 / 4.72"	120 / 4.72"
up to 1 800 / 70.87"	800 / 31.50"	up to 1 800 / 70.87"	850 / 33.46"	835 / 32.87"	835 / 32.87"
10 / 0.39"	10 / 0.39"	10 / 0.39"	10 / 0.39"	10 / 0.39"	10 / 0.39"
•	•	•	•	•	•
- / •	- / •	• / -	• / -	• / -	• / -
- / - / •	- / - / •	- / • / -	- / • / -	- / • / -	- / • / -
•	•	•	•	•	•
• / •	• / •	• / •	• / •	• / •	• / •
36	36	36	36	24	36
• / -	- / -	• / • [3]	• / • [3]	- / -	- / -
-	-	-	-	-	-
- / •	• / -	- / •	- / •	• / -	• / -
•	•	•	•	•	•
0.5	0.7	0.5	0.5	0.7	0.7
• / •	• / •	• / •	• / •	• / •	• / •
• / • / •	• / • / •	• / • / •	• / • / •	• / • / •	• / • / •
• / - / -	• / - / -	• / - / -	• / - / -	• / - / -	• / - / -
-	-	-	-	-	-
•	•	•	•	•	•
• / • / -	• / • / -	• / • / •	• / • / •	• / • / -	• / • / -
- / • / •	- / • / •	- / • / •	- / • / •	- / • / •	- / • / •
•	•	•	•	•	•
• / • / •	• / • / •	• / • / •	• / • / •	- / - / •	- / - / •
•	•	•	•	•	•
• / •	• / •	• / •	• / •	• / •	• / •
- / •	• / •	- / •	- / •	• / •	• / •
•	•	•	•	•	•
•	•	•	•	•	•
• / •	• / •	• / • [5]	• / • [5]	• / • [5]	• / • [5]
• / •	• / •	• / •	• / •	• / •	• / •

# EasyGate - Sliding Technology & Special Applications Overview



Type	LG	BG	LX/LH	FL/FH
Shape of cabinet - rounded / square	• / -	• / -	• / •	• / •
Available models - 1 wing / 2 wings	- / •	- / •	- / •	- / •
<b>Dimensions</b>				
Cabinet Height in mm (inches)	990 / 38.98"	990 / 38.98"	990 / 38.98"	990 / 38.98"
Cabinet Length in mm (inches)	1 550 / 61.02"	1 326 / 52.21"	1 700 / 66.93"	1 700 / 66.93"
Cabinet Width in mm (inches)	330 / 12.99"	330 / 12.99"	320 / 12.60"	320 / 12.60"
Glass wing barrier height in mm (inches)	up to 1 800 / 70.87"	950 / 37.40"	up to 1 800 / 70.87"	940 / 37.01"
Glass wing barrier thickness in mm (inches)	8 / 0.31"	8 / 0.31"	8 / 0.31"	10 / 0.39"
DDA (ADA) Compliant	•	-	•	•
<b>Standard Material</b>				
Stainless steel cabinet (AISI 304) / Special material	• / -	• / -	• / -	• / -
Stainless steel top lid (AISI 304) / Glass top Lid	• / -	- / •	• / -	• / -
<b>Safety Features</b>				
Emergency (Fire Alarm) input	•	•	•	•
Tailgating / Cross over	• / •	• / •	• / •	• / •
Number of sensor pairs (Transmitter / Receiver)	42	42	40	40
Pushthrough* / Pressure Sensing Top*	- / •	- / -	- / -	- / -
Induction loop system for detection of bicycles and scooters	-	-	-	-
Fail-Safe motor [1] / MDD motor	- / •	- / •	• / -	• / -
Safety & Security mode (5 settings)	•	•	•	•
Barrier opening time (s)	0.4	0.4	0.5	0.5
<b>Communication Interface</b>				
Relay Inputs / Outputs	• / •	• / •	• / •	• / •
RS485 / USB* / Ethernet* / Ethernet interface*	• / • / • / -	• / • / • / -	• / • / • / -	• / • / • / -
<b>Operating Environment</b>				
Indoor / Outdoor covered <sup>[7]</sup> / Outdoor uncovered	• / - / -	• / - / -	• / - / -	• / - / -
Extreme weather condition	-	-	-	-
<b>Optional Features</b>				
Integrated RFID reader bracket - flush mounted	•	•	•	•
Access Light / Lane Light / Edge Light	• / • / -	• / • / -	• / • / -	• / • / -
Wing Light / WAV Player	• [4] / •	• / •	• [4] / •	• / •
Identification or Ticket Terminals	•	•	•	•
Implementation of: Lift controller / Visitor Card collector / BarCode scanner	• / • / •	• / • / •	• / • / •	• / • / •
<b>Optional Remote Control Systems</b>				
Remote control (EasyTouch, TouchPanel)	•	•	•	•
TMON software application (remote control from any PC) / Passage Scheduler (automatic planner)	• / •	• / •	• / •	• / •
<b>Optional Power Supply Input</b>				
13.8V DC / 230V AC or 110V AC	- / •	- / •	• / •	• / •
SuperCap	•	•	•	•
<b>Optional Finishes</b>				
Custom surface finish	•	•	•	•
Custom Top Lid material / Custom cladding material	• / -	• / -	• / • [5]	• / • [5]
<b>Optional Mounting Accessories</b>				
Ramp LT / Mounting console	• / -	• / -	• / -	• / -

[1] Free-to-move without power  
• = Available

[2] Stainless steel tube wing  
\* = Not available

[3] Only with stainless steel Top Lid  
\* Optional accessories

[4] Only for 940 mm high glass wing  
[6] Different dimensions of cabinet

[5] Only for square cabinet

[7] The roof needs to overlap the turnstile sufficiently



# Options & Accessories



**EASYTOUCH** – turnstile remote control console with an intuitive graphical user interface



**TOUCHPANEL** – Touch-button panel for remote control of turnstiles and gates

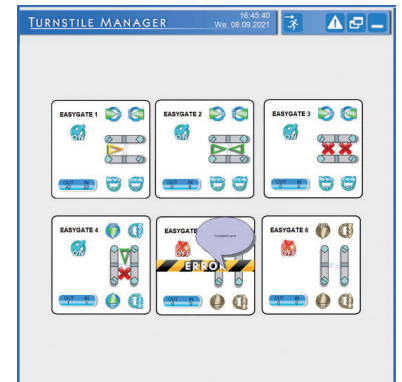

**TMON SOFTWARE** – software application for easy remote control of the turnstiles and gates



**RF REMOTE CONTROL** – for convenient remote opening of speed gates



**ACCESS LIGHT** – access control light with integrated RFID bracket



**LANE LIGHT** – front mounted lane accessibility light panel



**EDGE LIGHT** – information multicolour LED light belt

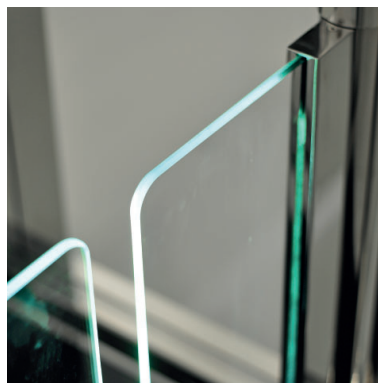

**WING LIGHT** – light illumination of glass wing barrier



**WAV PLAYER** – sound signaling device for audio confirmation of turnstile operation mode



**PRESSURE SENSING TOP** – pressure sensing device integrated in top lid to detect climb over

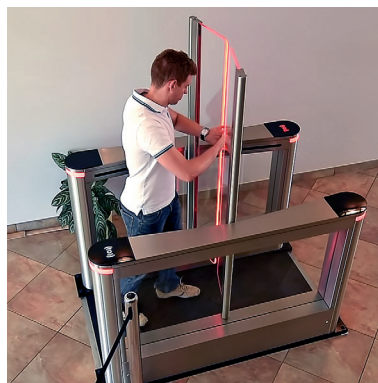

**PUSHTHROUGH** – allows the turnstiles to be set with the hard lock only in the entry direction



**SENSOR WALL** – optical sensors for EasyGate turnstile with wall mount





**CARD/BADGE COLLECTOR** – visitor card collector available in a stand-alone pole or Built-in versions.



**EASYSKAN** – RFID reader, Barcode and QR code scanner in one device, flush mouted in EasyGate cabinet.



**TICKETING TERMINAL** – external implementation of identification terminals

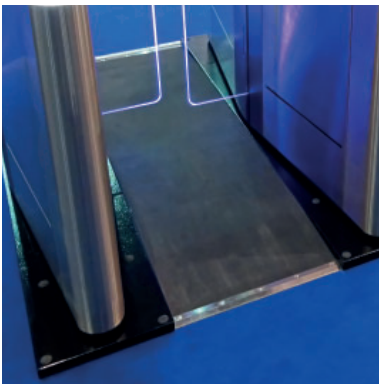

**RAMP LT** – for installation on floor where drilling/cutting is not allowed



**MOUNTING CONSOLE** – mounting console for raised/suspended floor



**GLASS INFILL BARRIER** – convenient way to aesthetically enclose the secure areas from public area



**ALTERNATIVE SURFACE FINISH** – polished stainless steel/brushed stainless steel/etc.



**BARCODE AND QR CODE SCANNER**



**ALTERNATIVE TOP LID** – wood, stone, corian, glass etc.



**LIFT CONTROLLER** – integration of lift controller



**PASSAGE LIGHT** – illumination of Top Lid edges, different operation modes



**SUPERCAP** – maintenance-free power package for Emergency opening of turnstile/gate

## Project Design

Every project varies in its specifics, it can therefore be hard to choose from a standard turnstile range. We want you to realise your project visions, thus we offer you a turnstile range that can be customised to your desires.

We always seek for the perfect solutions for your projects; whether you need a higher level of security or a change of colour, surface finish or cabinet styling; whether you desire a bespoke material or to integrate other devices into the turnstile; our team will provide expert guidance to help you customise your turnstile solutions, to unlock your imagination to create the turnstile that best fits your specifications.

As part of the service we are able to provide 3D images to help you visualise how your new turnstile will look in site.



EasyGate SPD with black painted pedestal and black corian cladding



EasyGate IM with a stone cladding

## EasyGate Integration

EasyGate Integration is a unique concept of integrating the EasyGate turnstile with other devices such as REA::Ticket terminal, EasyScan, RFID reader, Card/Badge collector, all developed by COMINFO and they are compatible with any 3rd party access control systems even with biometrics devices like facial recognition camera, fingerprint scanner, palm recognition, lift controller etc. All the integrations ensure direct communication between the speedgate and access control system, while maintaining the standard or customized cabinet design without external brackets, cables or other distracting elements.



EasyGate SPT with integrated MorphoWave contactless fingerprint scanner



All in one: Integration of RFID reader, barcode scanner, facial recognition camera and lift controller in EasyGate SPD cabinet while maintaining the standard dimensions



ed.IX-2022

Specifications are subject to change without prior notice.



**COMINFO, a.s.**

Nabrezi 695, 760 01 Zlín - Prstné, Czech Republic

T +420 603 151 333

cominfo@cominfo.cz

[www.cominfo.eu](http://www.cominfo.eu)

**cominfo**  
security first