

IT

MANUALE  
TECNICO

EN

TECHNICAL  
MANUAL

FR

MANUEL  
TECHNIQUE

NL

TECHNISCHE  
HANDLEIDING

DE

TECHNISCHES  
HANDBUCH

ES

MANUAL  
TÉCNICO

PT

MANUAL  
TÉCNICO

Kit monofamiliare Art. 8461I, 8461I/BM  
 Single-family Kit Art. 8461I, 8461I/BM  
 Kit un appel Art. 8461I, 8461I/BM  
 Enkelvoudige installatiekit Art. 8461I, 8461I/BM  
 Kit Einteilnehmerinstallation Art. 8461I, 8461I/BM  
 Kit unifamiliar Arts. 8461I y 8461I/BM  
 Kit monofamiliar Art. 8461I, 8461I/BM

**Comelit**  
 Passion. Technology. Design.

6601W/  
6601W/BM

[FULL MANUAL]

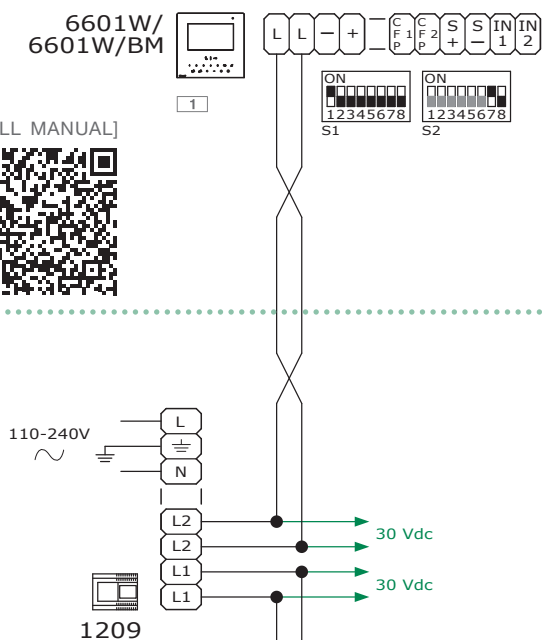

1209

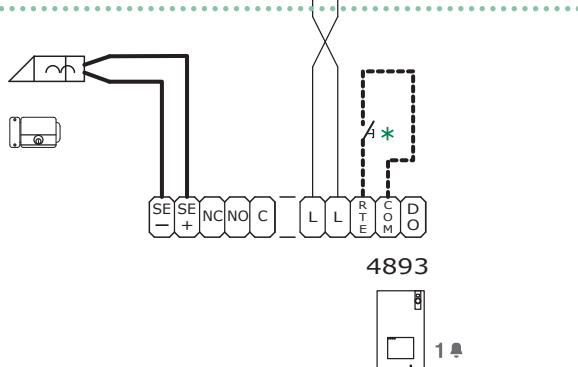

[FULL MANUAL]



- \* Pulsante comando apriporta locale
- \* Local lock release button
- \* Bouton ouvre-porte sortie
- \* Lokale bedieningsknop deuropenen
- \* Taste lokaler Türöffner
- \* Pulsador abrepuertas local
- \* Botão de comando de abertura da porta local

## Art. 1209

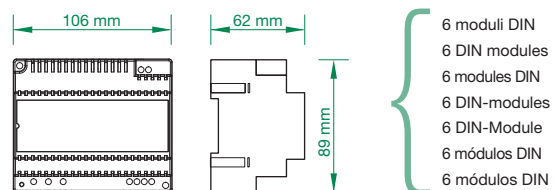

- IT** È necessario installare a monte dell'impianto videocitofonico un appropriato interruttore di rete onnipolare con apertura del contatto di almeno 3mm.
- Togliere l'alimentazione prima di effettuare qualsiasi operazione.
  - Rimettere le protezioni sui morsetti.
  - Non ostruire le aperture o fessure di ventilazione e di dissipazione del calore.
- EN** A suitable omnipolar switch with a contact opening of at least 3mm must be installed upstream of the video entry phone system.
- Cut off the power supply before carrying out any maintenance procedures.
  - Replace the protections on the terminals.
  - Do not obstruct the ventilation and cooling slits or openings
- FR** Installer un interrupteur de réseau omnipolaire avec ouverture de contact d'au moins 3mm en amont de l'installation vidéophonique.
- Couper l'alimentation avant d'effectuer toute opération.
  - Reposer les protections sur les bornes.
  - Ne pas gêner les ouvertures ou les fentes d'aération et de dissipation de la chaleur.
- NL** Aan de basis van het video-deurintercomsysteem moet een geschikte meerpolaire netschakelaar zijn aangebracht met een contactopening van ten minste 3mm.
- Sluit de voeding af voordat u onderhoudswerkzaamheden uitvoert.
  - Zet de beschermingen terug op de klemmen.
  - Sluit de ventilatie-openingen of spleten voor de warmte-afvoer niet af.
- DE** Vor der Video-Türsprechanlage muss ein allpoliger Netzschalter mit einer Kontaktöffnung von mindestens 3 mm installiert werden.
- Vor Eingriffen an der Anlage immer die Spannungsversorgung unterbrechen.
  - Die Schutzabdeckungen der Klemmen wieder anbringen.
  - Die Öffnungen und Schlitze zur Belüftung und Wärmeableitung nicht verschließen.
- ES** Es necesario instalar, aguas arriba de la instalación de videoportero, un interruptor de red omnipolar con una distancia de apertura de los contactos de al menos 3 mm.
- Antes de efectuar cualquier operación hay que cortar la alimentación.
  - Colocar las protecciones en los bornes.
  - No tapan las aberturas o ranuras de ventilación y disipación de calor.
- PT** É necessário instalar a montante do equipamento vídeo-intercomunicador um interruptor de rede omnipolar adequado com uma abertura de contacto de pelo menos 3 mm.
- Cortar a alimentação eléctrica antes de realizar qualquer tipo de operação.
  - Voltar a colocar as protecções nos bornes.
  - Não obstruir as aberturas ou fendas de ventilação e de dissipação de calor.

IK/039QC

IT Distanze di funzionamento  
 EN Operating distances  
 FR Distances de fonctionnement

NL Afstanden  
 DE Maximal zulässige Entfernungen

ES Distancias de funcionamiento  
 PT Distâncias de funcionamento

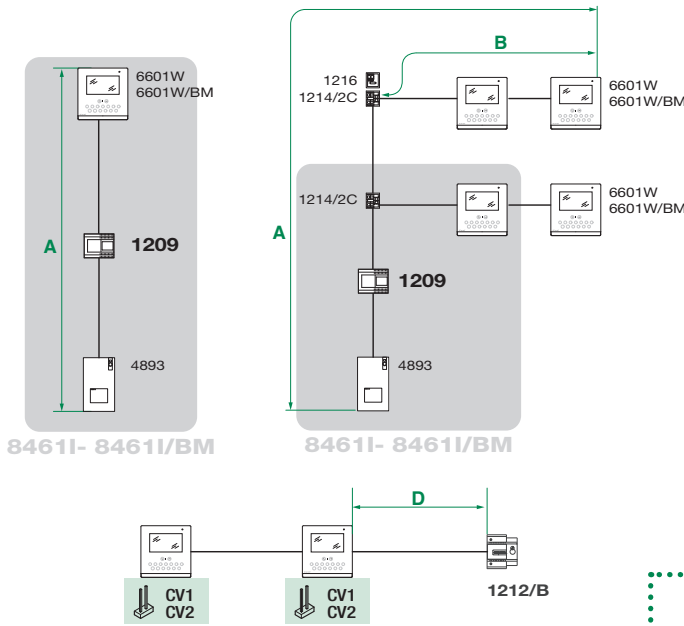

	A MAX	B MAX	D MAX
Cornelit Art. 4577/4579 1 mm <sup>2</sup> (Ø 1,2 mm AWG 17)	200 m (655 feet)	100 m (330 feet)	100 m (328 feet)
UTP5 cat. 5 0,2 mm <sup>2</sup> (Ø 0,5 mm AWG 24)	100 m (330 feet)	60 m (195 feet)	
0,28 mm <sup>2</sup> (Ø 0,6 mm AWG 23)	100 m (330 feet)	60 m (195 feet)	10 m (32,5 feet)
0,5 mm <sup>2</sup> (Ø 0,8 mm AWG 20)	100 m (330 feet)	60 m (195 feet)	25 m (82 feet)
1 mm <sup>2</sup> (Ø 1,2 mm AWG 17)	100 m (330 feet)	60 m (195 feet)	50 m (164 feet)
1 mm <sup>2</sup> (Ø 1,2 mm AWG 17)	80 m (260 feet)	40 m (130 feet)	
1,5 mm <sup>2</sup> (Ø 1,4 mm AWG 15)	100 m (330 feet)	60 m (195 feet)	100 m (328 feet)
*UTP5 cat. 5 0,2 mm <sup>2</sup> (Ø 0,5 mm AWG 24) MULTI PAIR CABLE			
GREEN GREEN / WHITE ORANGE / WHITE ORANGE BLU BLU / WHITE BROWN / WHITE BROWN	200 m (656 feet)	70 m (230 feet)	

**i** IT \*Cavo UTP con connessione multi-coppia: RISPETTARE I COLORI INDICATI IN FIGURA!  
 EN \*UTP cable with multi-cable connection: FOLLOW THE COLOURS SHOWN IN THE DIAGRAM!  
 FR \*Cable UTP avec connexion paires torsadées multiples : RESPECTER LES COULEURS INDIQUÉES DANS LA FIGURE !

NL \*UTP-kabel met multi-paar aansluiting: DE IN DE AFBELDING AANGEGEVEN KLEUREN AANHOUDEN!  
 DE \*UTP-Kabel mit Doppeladerbündel-Anschluss DIE IN DER ABBILDUNG ANGEGBENEN FARBEN BEACHTEN!  
 ES \*Cable UTP con conexión multipar: ¡RESPECTAR LOS COLORES INDICADOS EN LA FIGURA!  
 PT \*Cabo UTP com ligação multi-par: RESPEITAR AS CORES INDICADAS NA IMAGEM!

IT Massima espansione per appartamento NL Maximale uitbreiding per appartement ES Máxima expansión por vivienda  
 EN Maximum expansion per apartment DE Maximale Erweiterung pro Wohnung PT Máxima expansão por apartamento  
 FR Extension maximale par appartement

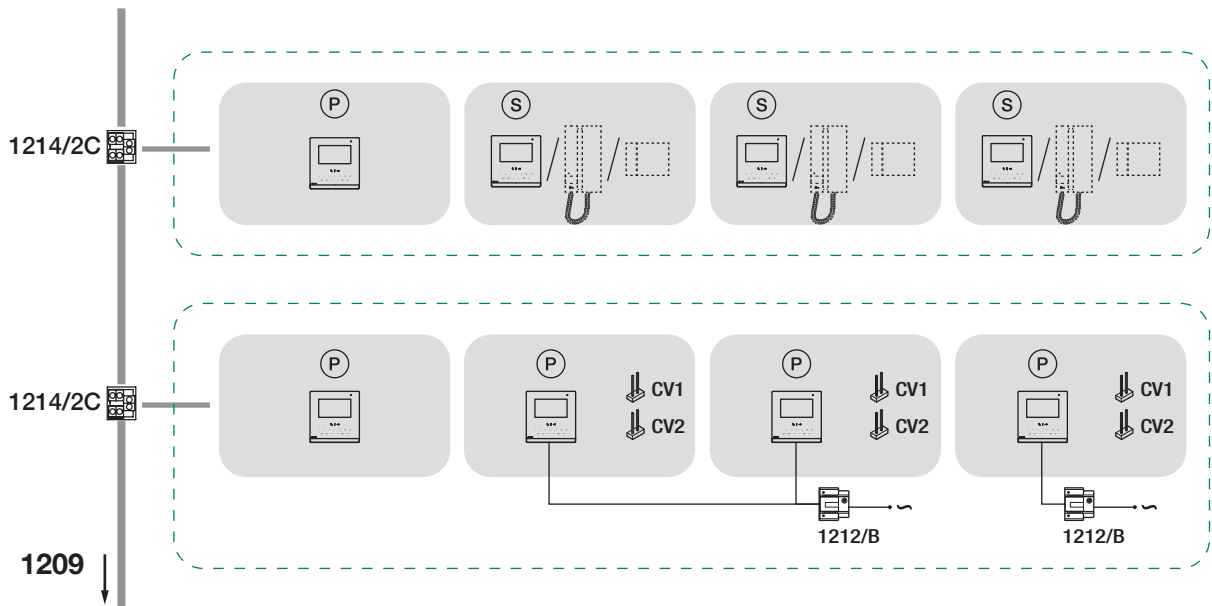

□ = 1229 / 1229A

CERTIFIED MANAGEMENT SYSTEMS



www.comelitgroup.com

Via Don Arrigoni, 5 - 24020 Rovetta (BG) - Italy



3ª edizione 06/2017  
 cod. 2G40001951